



**OPERATION AND SERVICE MANUAL**

**8569B**  
**SPECTRUM ANALYZER**  
Includes Options 001 and 002

**SERIAL NUMBERS**

This manual applies directly to HP Model 8569B Spectrum Analyzers having serial prefix number 2244A.

For additional important information about serial numbers see INSTRUMENTS COVERED BY MANUAL in Section I.

*volume 1* **GENERAL INFORMATION**  
**INSTALLATION AND OPERATION VERIFICATION**  
**OPERATION**

Copyright © 1982, HEWLETT-PACKARD COMPANY  
1424 FOUNTAIN GROVE PARKWAY, SANTA ROSA, CALIFORNIA, 95404, U.S.A.

MANUAL PART NO. 08569-90032

Printed: December 1982

# **HP MANUAL SCANS**

**By**

***Artek Media***

1042 Plummer Cir. SW  
Rochester, MN 55902

[www.artekmedia.com](http://www.artekmedia.com)

"High resolution scans of obsolete technical manuals"

**ALL HP MANUALS ARE REPRODUCED  
WITH PERMISSION OF  
AGILENT TECHNOLOGIES INC.**

**Reproduction of this scanned document or removal of this disclaimer  
Will be considered in violation of both Agilent's and Artek Media's copy rights**

If your looking for a quality scanned technical manual in PDF format please visit our WEB site at [www.artekmedia.com](http://www.artekmedia.com) or drop us an email at [manuals@artekmedia.com](mailto:manuals@artekmedia.com) and we will be happy to email you a current list of the manuals we have available.

If you don't see the manual you need on the list drop us a line anyway we may still be able to point you to other sources. If you have an existing manual you would like scanned please write for details, This can often be done very reasonably in consideration for adding your manual to our library.

Typically the scans in our manuals are done as follows;

- 1) Typed text pages are typically scanned in black and white at 300 dpi.
- 2) Photo pages are typically scanned in gray scale mode at 600 dpi
- 3) Schematic diagram pages are typically scanned in black and white at 600 dpi unless the original manual had colored high lighting (as is the case for some 70's vintage Tektronix manuals).

Thanks

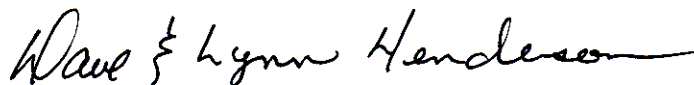

Dave & Lynn Henderson  
Artek Media

**CONTENTS**

Section	Page	Section	Page
<b>I GENERAL INFORMATION</b> . . . . .	1-1	2-3. Initial Inspection . . . . .	2-1
1-1. Introduction . . . . .	1-1	2-5. Preparation for Use . . . . .	2-1
1-3. Description . . . . .	1-1	2-25. Storage and Shipment . . . . .	2-7
1-9. Manual Organization . . . . .	1-1	2-31. Operation Verification . . . . .	2-7
1-11. Specifications . . . . .	1-1	2-33. Operational Check . . . . .	2-8
1-13. Safety Considerations . . . . .	1-2	2-34. Tuning Accuracy . . . . .	2-8
1-18. Instruments Covered By Manual . . . . .	1-3	2-35. Frequency Span Width and Resolution Bandwidth Accuracy . . . . .	2-10
1-27. Options . . . . .	1-3	2-36. Amplitude Accuracy . . . . .	2-12
1-40. Accessories Supplied . . . . .	1-4		
1-42. Equipment Available . . . . .	1-4		
1-49. Recommended Test Equipment . . . . .	1-4		
<b>II INSTALLATION AND OPERATION VERIFICATION</b> . . . . .	2-1	<b>III OPERATION</b> . . . . .	3-1
2-1. Introduction . . . . .	2-1	3-1. Introduction . . . . .	3-1
		3-4. Routine Maintenance . . . . .	3-1

**LIST OF ILLUSTRATIONS**

Figure	Page	Figure	Page
1-1. HP Model 8569B Spectrum Analyzer with Accessories Supplied . . . . .	1-0	2-2. Attaching Rack Mounting Hardware and Handles . . . . .	2-5
1-2. Typical Serial Number Plate . . . . .	1-3	2-3. Packaging for Shipment Using Factory Packaging Materials . . . . .	2-6
1-3. Service Accessories Package . . . . .	1-12	2-4. Operation Verification Test Setup . . . . .	2-9
2-1. Line Voltage Selection with Power Module PC Board . . . . .	2-4	2-5. Span Width Accuracy Measurement . . . . .	2-11

**LIST OF TABLES**

Table	Page	Table	Page
1-1. HP Model 8569B Specifications . . . . .	1-5	2-1. AC Power Cables Available . . . . .	2-2
1-2. HP Model 8569B Supplemental Characteristics . . . . .	1-8	2-2. Rack-Mounting Kits for HP 8569B . . . . .	2-3
1-3. Recommended Test Equipment . . . . .	1-14	2-3. Operational Check . . . . .	2-14
		2-4. Operation Verification Test Record . . . . .	2-17

HP 8569B

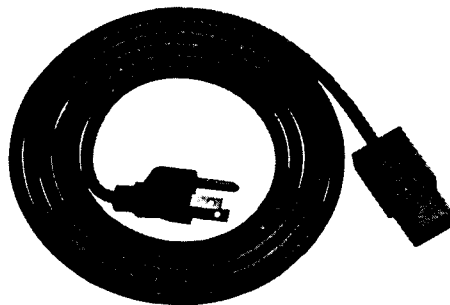

**LINE POWER CABLE**

**(SEE TABLE 2-1 FOR  
HP PART NUMBER)**

*Figure 1-1. HP Model 8569B Spectrum Analyzer with Accessories Supplied*

## SECTION I GENERAL INFORMATION

### 1-1. INTRODUCTION

1-2. This Operation and Service manual contains information required to install, operate, test, adjust, and service the Hewlett-Packard Model 8569B Spectrum Analyzer. Figure 1-1 shows the instrument and accessories supplied. This section covers instrument identification, description, options, accessories, specifications, and other basic information.

### 1-3. DESCRIPTION

1-4. The HP Model 8569B Spectrum Analyzer provides a visual display of RF and microwave signals in the frequency domain. Input signal amplitude is plotted on the CRT as a function of frequency.

1-5. The HP Model 8569B is designed for simplicity of operation. Most measurements can be made using only three controls, once the normal settings (marked in green) have been preset. The HP Model 8569B has absolute amplitude and frequency calibration from 10 MHz to 22 GHz. The frequency span, bandwidth, and video filter are all coupled with automatic sweep time to maintain a calibrated display and to simplify operation of the analyzer.

1-6. Internal preselection eliminates most spurious images and multiple responses to simplify signal identification. The preselector also extends dynamic range of the analyzer and provides some protection for the input mixer.

1-7. The frequency range of the HP Model 8569B is 10 MHz to 22 GHz in direct coaxial input and 12.4 to 115 GHz when used with external mixers.

1-8. The HP Model 8569B has a digital display with the spectral information contained in either of two independent traces. Major control settings are annotated on the CRT above the graticule area. Signal processing controls for the digital display include trace normalization, a maximum hold function, digital averaging, and trace storage. A hard-copy record of the display may be obtained through direct instrument control of listen-only plotters. The HP Model 8569B has an HP-IB capability that allows controller interrogation of display information or controller entry of messages and trace data.

### 1-9. MANUAL ORGANIZATION

1-10. This manual is divided into eight sections as follows:

SECTION I, GENERAL INFORMATION, contains the instrument description and specifications, explains accessories and options, and lists recommended test equipment.

SECTION II, INSTALLATION AND OPERATION VERIFICATION, contains information concerning initial mechanical inspection, preparation for use, operating environment, packaging and shipping, and operation verification.

SECTION III, OPERATION, contains detailed operating instructions for operation of the instrument.

SECTION IV, PERFORMANCE TESTS, contains the necessary tests to verify that the electrical operation of the instrument is in accordance with published specifications.

SECTION V, ADJUSTMENTS, contains the necessary adjustment procedures to properly adjust the instrument after repair.

SECTION VI, REPLACEABLE PARTS, contains the information necessary to order parts and/or assemblies for the instrument.

SECTION VII, MANUAL BACKDATING CHANGES, contains backdating information to make this manual compatible with earlier equipment configurations.

SECTION VIII, SERVICE, contains schematic diagrams, block diagrams, component location illustrations, circuit descriptions, and troubleshooting information to aid in repair of the instrument.

### 1-11. SPECIFICATIONS

1-12. Instrument specifications are listed in Table 1-1. These specifications are the performance standards or limits against which the instrument is tested.

Table 1-2 lists supplemental characteristics. Supplemental characteristics are not specifications but are typical characteristics included as additional information for the user.

**NOTE**

**To ensure that the HP Model 8569B meets the specifications listed in Table 1-1, performance tests (Section IV) should be performed every six months.**

**1-13. SAFETY CONSIDERATIONS**

1-14. Before operating this instrument, you should familiarize yourself with the safety markings on the instrument and safety instructions in this manual. This instrument has been manufactured and tested according to international safety standards. However, to ensure safe operation of the instrument and personal safety of the user and service personnel, the cautions and warnings in this manual must be followed. Refer to individual sections of this manual for detailed safety notation concerning the use of the instrument as described in those individual sections.

**1-15. Safety Symbols**



Instruction manual symbol: the apparatus will be marked with this symbol when it is necessary for the user to refer to the instruction manual in order to protect the apparatus against damage.



Indicates dangerous voltages.



Earth terminal



The **WARNING** sign denotes a hazard. It calls attention to a procedure, practice, or the like, which, if not correctly performed or adhered to, could result in injury or loss of life. Do not proceed beyond a **WARNING** sign until the indicated conditions are fully understood and met.



The **CAUTION** sign denotes a hazard. It calls attention to an operating procedure, practice, or the like, which, if not correctly performed or adhered to, could result in damage to or destruction of part or all of the equipment. Do not proceed beyond a **CAUTION** sign until the indicated conditions are fully understood and met.

**1-16. Service**

1-17. Although this instrument has been manufactured in accordance with international safety standards, this manual contains information, cautions, and warnings which must be followed to insure safe operation and to keep the instrument safe. Service should be performed only by qualified service personnel, and the following warnings should be observed:



**Any maintenance or repair of the opened instrument under voltage should be avoided as much as possible, and when inevitable, should be carried out only by a skilled person who is aware of the hazard involved.**

**Capacitors inside the instrument may still be charged even if the instrument has been disconnected from its source of supply.**

**Make sure that only fuses with the required rated current and of the specified type (normal blow, time delay, etc.) are used for replacement. The use of repaired fuses and the short-circuiting of fuseholders must be avoided.**

**When it is likely that the protection has been impaired, the instrument must be made inoperative and be secured against any unintended operation.**

**If this instrument is to be energized via an auto-transformer (for voltage reduction) make sure the common terminal is connected to the earthed pole of the power source.**

**BEFORE SWITCHING ON THE INSTRUMENT, the protective earth terminals of the instrument must be connected to the protective conductor of the mains power cord. The mains plug shall only be inserted in a socket outlet provided with a protective earth contact. The protective action must not be negated by the use of an extension cord (power cord)**

without a protective conductor (grounding). Grounding one conductor of a two conductor outlet is not sufficient protection.

Any interruption of the protective (grounding) conductor (inside or outside the instrument) or disconnecting the protective earth terminal is likely to make this instrument dangerous.



**BEFORE SWITCHING ON THIS INSTRUMENT, make sure instrument's ac input is set to the voltage of the ac power source (see Figure 2-1).**

**BEFORE SWITCHING ON THIS INSTRUMENT, make sure the ac line fuse is of the required current rating and type (normal-blow, time delay, etc.).**

**1-18. INSTRUMENTS COVERED BY MANUAL**

**1-19. Serial Numbers**

1-20. Attached to the rear of each section of your instrument is a serial number plate (Figure 1-2). The serial number is in two parts. The first four digits and letter are the serial number prefix; the last five digits are the suffix. The prefix is the same for all identical instruments; it changes only when a change is made to the instrument. The suffix, however, is assigned sequentially and is different for each instrument. The contents of this manual apply to instruments with the serial number prefix(es) listed under SERIAL NUMBERS on the title page.

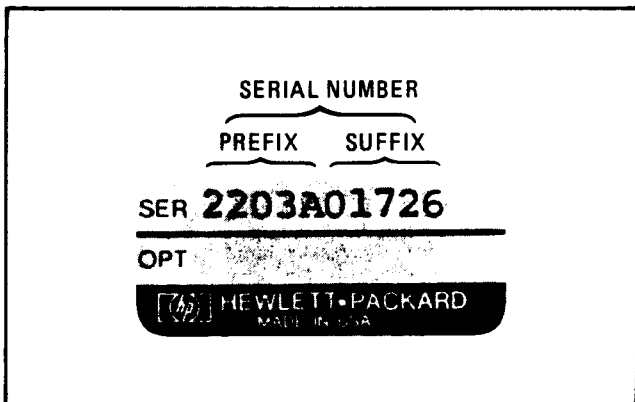

Figure 1-2. Typical Serial Number Plate

**1-21. Manual Changes Supplement**

1-22. An instrument manufactured after the printing of this manual may have a serial number prefix that is not listed on the title page. This unlisted serial number prefix indicates the instrument is different from those described in this manual. The manual for this newer instrument is accompanied by a yellow Manual Changes supplement. This supplement contains "change information" that explains how to adapt the manual to the newer instrument.

1-23. In addition to change information, the supplement may contain information for correcting errors in the manual. To keep this manual as current and accurate as possible, Hewlett-Packard recommends that you periodically request the latest Manual Changes supplement. The supplement carries a manual identification block that includes the model number, print date of the manual, and manual part number. Complimentary copies of the supplement are available from Hewlett-Packard. Addresses of Hewlett-Packard offices are located at the back of this manual.

**1-24. Manual Backdating Changes**

1-25. Instruments manufactured before the printing of this manual have been assigned serial number prefixes other than those for which this manual was written directly. Manual backdating information is provided in Section VII to adapt this manual to any such earlier assigned serial number prefix.

1-26. This information should not be confused with information contained in the yellow Manual Changes supplement, which is intended to adapt this manual to instruments manufactured after the printing of this manual.

**1-27. OPTIONS**

**1-28. Option 001**

1-29. Option 001 provides an internally connected, 100-MHz comb generator that is switched in by a front-panel push button.

**1-30. Option 002**

1-31. Option 002 deletes the two most narrow RESOLUTION BW settings, .3 kHz and .1 kHz, provided on the standard instrument.

**1-32. Option 400**

1-33. Option 400 permits operation on 50, 60, and 400 Hz mains. All specifications are identical to those of the standard HP Model 8569B except for operating temperature range and power requirements (see Table 1-1).

**1-34. Option 908, Rack Flange Kit**

1-35. Option 908, HP Part Number 5061-0078, includes flanges and hardware required to mount the HP Model 8569B in an equipment rack with horizontal spacing of 482.6 mm (19 in.). See Figure 2-2 for installation procedure.

**1-36. Option 910, Additional Operation and Service Manual**

1-37. One additional Operation and Service Manual is provided for each Option 910 ordered.

To obtain Option 910 after shipment of the instrument, specify the manual part number printed on the title page of the manual.

**1-38. Option 913, Rack Flange/Front Handle Kit**

1-39. Option 913, HP Part Number 5061-0084, combines a Front Handle Kit with Option 908, Rack Flange Kit. See Figure 2-2 for installation procedure.

**1-40. ACCESSORIES SUPPLIED**

1-41. Figure 1-1 shows the HP Model 8569B Spectrum Analyzer and line power cord. One 50-ohm termination (HP 1810-01180, connected to the front-panel 1ST LO OUTPUT port, is also supplied.

**1-42. EQUIPMENT AVAILABLE****1-43. Service Accessories**

1-44. A Service Accessories Package is available for convenience in aligning and troubleshooting the spectrum analyzer. The Service Accessories Package is shown in Figure 1-3. The package may be obtained from Hewlett-Packard by ordering HP Part Number 08569-60035.

**1-45. Measurement Accessories**

**1-46. HP Model 11517A External Mixer.** This mixer extends the frequency range of the HP Model 8569B to 40 GHz. Transition sections (HP Models 11518, 11519A, and 11520A) are available to adapt the HP Model 11517A External Mixer to standard waveguide sizes.

**1-47. HP Model 197B, Option 006 Oscilloscope Camera.** This camera can be used with the Model 8569B to make a permanent record of measurements.

**1-48. Transit Case.** A polyethylene transit case, HP Part Number 1540-0654, is available for protection of the HP 8569B Spectrum Analyzer.

**1-49. RECOMMENDED TEST EQUIPMENT**

1-50. Equipment required for operation verification, performance tests, adjustments, and troubleshooting of the HP Model 8569B is listed in Table 1-3. Other equipment may be substituted if it meets or exceeds the critical specifications listed in the table.



Table 1-1. HP Model 8569B Specifications (1 of 3)

## SPECIFICATIONS

### FREQUENCY SPECIFICATIONS

#### FREQUENCY RANGE

##### Internal mixing 0.01 to 22 GHz

Covered in six ranges selectable by Frequency Band push buttons (in GHz): .01 to 1.8; 1.7 to 4.1; 3.8 to 8.5; 5.8 to 12.9; 8.5 to 18; 10.5 to 22.

##### External mixing 12.4 to 115 GHz

Covered in four ranges selectable by Frequency Band push buttons (in GHz): 12.4–26.5 (6+ harmonic mode); 21–44 (10+ harmonic mode); 33–71 (16+ harmonic mode); and 53–115 (26+ harmonic mode).

#### FREQUENCY ACCURACY

##### Tuning Accuracy

The overall tuning accuracy of the digital frequency readout in any span mode:

##### .01 to 115 GHz

$\pm$ (5 MHz or 0.2% of center frequency, whichever is greater, + 20% of frequency span per division)

##### CRT digital readout resolution (included in tuning accuracy)

Internal mixing, 100 kHz; external mixing, 1 MHz

#### FREQUENCY SPANS

(on a 10 division CRT horizontal axis)

##### 1.7 to 22 GHz

Multiband span of spectrum from 1.7 to 22 GHz in one sweep. The frequency (position) corresponding to the tuning marker is set by the Tuning control and indicated by the digital frequency displays on the front panel and the CRT.

##### Full Band

Displays spectrum of entire Frequency Band selected. Tuning marker displayed in Full Band mode (becomes center frequency when Per Division mode is selected). Marker frequency is given on the digital displays.

##### Per Division

Eighteen calibrated spans from 1 kHz/Div to 500 MHz/Div in a 1, 2, 5, 10 sequence. In "F" position the entire Frequency Band selected is spanned.

##### Span width accuracy

The frequency error for any two points on the display for spans from 500 MHz to 20 kHz/Div (unstabilized) is less than  $\pm$ 5% of the indicated separation; for stabilized spans 100 kHz/Div and less, the error is less than  $\pm$ 15%.

##### Center Frequency

The center frequency represented by the CRT is indicated by the digital frequency displays on the front panel and the CRT.

##### Zero Span

Analyzer becomes a manually tuned receiver (for the time domain display of signal modulation) set to the frequency indicated by the digital frequency displays.

### SPECTRAL RESOLUTION AND STABILITY

#### Resolution Bandwidths

Resolution (3 dB) bandwidths from .1 kHz to 3 MHz in 1, 3 sequence. Bandwidth may be varied independently or coupled to Frequency Span/Div control. Optimum coupling (convenient ratio of Frequency Span/Div to Resolution Bandwidth) is indicated by alignment of markers ( $\blacktriangleright$   $\blacktriangleleft$ ) on both controls.

Uncoupled, the controls for Frequency Span/Div and Resolution Bandwidth may be independently set so any resolution bandwidth (3 MHz to .1 kHz) may be used with any span width (F and 500 MHz to 1 kHz/Div). Analyzer is calibrated if UNCAL is not displayed.

#### Resolution Bandwidth accuracy

Individual resolution bandwidth 3 dB points:  
<  $\pm$  15%.

**Selectivity:** (60 dB/3 dB bandwidth ratio) < 15:1 for bandwidths 3 kHz to 3 MHz; < 11:1 for bandwidths .1 kHz to 1 kHz.

#### Stability

##### Total residual FM

Stabilized: < 100 Hz p-p in 0.1 sec, .01 – 4.1 GHz  
Unstabilized: < 10 kHz p-p in 0.1 sec, .01 – 4.1 GHz  
(Fundamental mixing)

**Stabilization range:** First LO automatically stabilized (unless auto stabilizer is OFF) for frequency spans 100 kHz/Div or less.

**Noise sidebands:** At least 75 dB down, greater than 30 kHz from center of CW signal when set to a 1 kHz Resolution Bandwidth and a 10 Hz (.01) Video Filter (fundamental mixing).

### AMPLITUDE SPECIFICATIONS

#### AMPLITUDE RANGE — Internal mixer

##### Measurement range:

##### Damage levels:

**Total RF power:** +30 dBm (1 watt)

**dc or ac** (< < 50 $\Omega$  source impedance):

0V with 0 dB input attenuation (1 amp);  $\pm$  7V with  $\geq$  10 dB input attenuation (0.14 amp)

Table 1-1 HP Model 8569B Specifications (2 of 3)

**Peak pulse power:**

+ 50 dBm (<10 μsec. pulse width, 0.01% duty cycle), ≥ 20 dB attenuation

**Gain compression:**

< 1 dB for -7 dBm input level with 0 dB attenuation.

**Average Noise Level:**

Sensitivity (minimum discernible signal) is given by the signal level which is equal to the average noise level, causing approximately a 3-dB peak above the noise. Maximum average noise level with 1 kHz Resolution Bandwidth (0 dB attenuation and 0.003 (3 Hz) video filter) is given in the table below. Sensitivity in the external mixing bands (harmonic modes 6+, 10+, 16+ and 26+) assumes an external mixer conversion loss of 30 dB.

Frequency Band (GHz)	First IF in MHz	Harmonic Mode	Avg. Noise Level (dBm)
.01-1.8	2050	1-	-113
1.7-4.1	321.4	1-	-110
3.8-8.5	321.4	2-	-107
5.8-12.9	321.4	3-	-100
8.5-18	321.4	4+	-95
10.5-22	321.4	5+	-90
12.4-26.5	321.4	6+	-104
21-44	321.4	10+	-104
33-71	321.4	16+	-104
53-115	321.4	26+	-104

**Reference Level**

**Reference Level range:** +60 dBm<sup>1</sup> to -112 dBm in 10 dB steps and continuous 0 to -12 dB calibrated vernier.

**Reference Level accuracy:**

With Sweep Time/Division control in Auto setting, the optimum sweep rate is selected automatically for any combination of Frequency Span/Div, Resolution Bandwidth and Video Filter settings. Thus, the Auto Sweep setting insures a calibrated amplitude display within the following limits:

**Calibrator output**

-10 dBm ± 0.3 dB  
100 MHz ± 10 kHz

**Reference Level variation (Input Attenuator at 0 dB)**

10 dB steps, +20°C to +30°C:  
-10 to -70 dBm: < ± 0.5 dB  
-10 to -100 dBm: < ± 1.0 dB  
-10 to -70 dBm: < ± 1.0 dB, 0°C to +55°C

**Vernier (0 to -12 dB) continuous:** Maximum error < ± 0.5 dB, when read from Reference Level Fine control.

**Input Attenuator (at preselector input, 70 dB range in 10 dB steps)**

**Step size variation:**

0 to 60 dB, 0.01-18 GHz: < ± 1.0 dB  
0 to 40 dB, 0.01-22 GHz: < ± 1.5 dB

**Maximum cumulative error:**

0 to 60 dB, 0.01-18 GHz: < ± 2.4 dB  
0 to 40 dB, 0.01-22 GHz: < ± 2.5 dB

**Frequency Response (with 0 or 10 dB of Input Attenuation)**

Frequency response includes input attenuator, preselector and mixer frequency response plus mixing mode gain variation (band to band) and assumes preselector peaking.

Frequency Band (GHz)	Frequency Response (± dB MAX.)
.01-1.8	1.2
1.7-4.1	1.5
3.8-8.5	2.5
5.8-12.9	2.5
8.5-18	3.0
10.5-22	4.5

**Switching between bandwidths:** 3 MHz to 300 kHz, < ± 0.5 dB; 3 MHz to 0.1 kHz, < ± 1.0 dB.

**Calibrated display range**

**Log expanded from reference level down:**

70 dB with 10 dB/Div scale factor  
40 dB with 5 dB/Div scale factor  
16 dB with 2 dB/Div scale factor  
8 dB with 1 dB/Div scale factor

**Linear:** Full scale from 0.56 μV (-112 dBm across 50 ohms to 224 volts (+60 dBm)<sup>1</sup> in 10 dB steps and continuous 0 to -12 dB vernier. Full scale signals in linear translate to approximately full scale signals in the log modes.

**Display accuracy**

**Log:** < ± 0.1 dB/dB but not more than ± 1.5 dB over 70 dB display range.

**Linear:** < ± 3% of reference level.

**Residual responses (no signal present at input):**

With 0 dB input attenuation and fundamental mixing (0.01 to 4.1 GHz): < -90 dBm.

**Signal Identifier:**

Provided over entire frequency range and in all Frequency Span/Div. settings. Correct response is a 2 MHz shift to left and approximately a 6 dB lower amplitude. (Reads incorrectly for 100 MHz CAL OUTPUT Signal.)

<sup>1</sup> Input level not to exceed +30 dBm damage level.

Table 1-1. HP Model 8569B Specifications (3 of 3)

**SWEEP SPECIFICATIONS**

**SWEEP TIME**

**Auto:** Sweep time is automatically controlled by Frequency Span/Div, Resolution Bandwidth and Video Filter controls to maintain an absolute amplitude calibrated display.

**Calibrated Sweep times:** 21 internal sweep times from 2  $\mu$ sec/Div to 10 sec/Div in 1, 2, 5 sequence. Sweep time accuracy  $\pm 10\%$  except for 2, 5, and 10 sec/Div, which are  $\pm 20\%$ . Swept frequency modes use sweep times 2 msec/Div through 10 sec/Div. When operated as a fixed tuned receiver (Zero Span) the full range of sweep times (2  $\mu$ sec to 10 sec/Div) may be used to display modulation waveforms. Sweep times that are too fast or too slow for the Resolution Bandwidth, Frequency Span/Div, and Video Filter settings (producing an uncalibrated display) are indicated by an UNCAL warning on the CRT. Sweep times  $\leq 2$  msec/Div ( $\leq 5$  msec/Div when in Max Hold, Digital Averaging, or INP-B $\rightarrow$ A Normalization) produce a mixed mode display with analog traces and CRT control readouts on the CRT.

**GENERAL SPECIFICATIONS**

**LO OUTPUT (2.00 to 4.46 GHz):**

- +7 dBm minimum, 0 to 35°C;
- +5 dBm minimum, 35 to 55°C.

**TEMPERATURE RANGE:**

- Operating 0°C to 55°C
- Storage -40°C to +75°C.

**HUMIDITY RANGE (Operating):**

- < 95% R.H. 0°C to +40°C.

**EMI:**

Conducted and radiated interference is in compliance with MID-STD 461A Methods CEO3 and REO2, CISPR publication 11 (1975) and Messemppfaenger- Postverfuegung 526/527/79 (Kennzeichnung Mit F- Nummer/Funkschutzzeichen).

**POWER REQUIREMENTS**

48-66 Hz; 100, 120, 220 or 240 volts (-10% to +5%); 220 VA maximum. Fan cooled.

**WEIGHT:**

- Net: 29.1 kg (64 lbs.)
- Shipping: 40.9 kg (90 lbs.)

**DIMENSIONS**

458 mm wide: 188 mm high, 565 mm deep (18 in. x 7 3/8 in. x 22 1/4 in.)

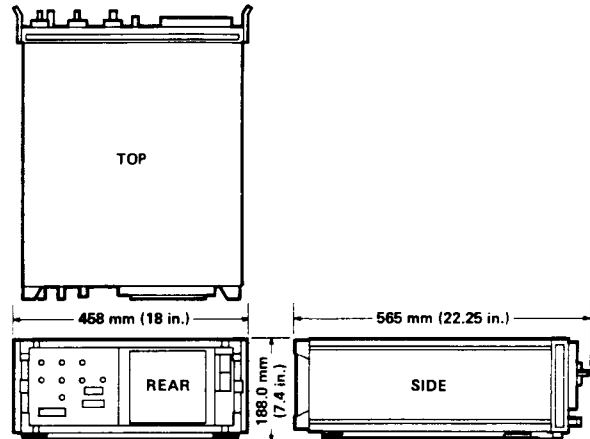

**STANDARD OPTIONS AVAILABLE**

**OPTION 001**

- Internal 100 MHz Comb Generator**
- Frequency Range:** 0.01 to 22 GHz
- Frequency Accuracy:**  $\leq \pm 0.007\%$

**OPTION 002**

Deletes .3 kHz and .1 kHz resolution BW settings.

**All specifications identical to standard HP 8569B except: Spectral Resolution and Stability**

**Resolution Bandwidths:** Resolution (3 dB) bandwidths from 1 kHz to 3 MHz in a 1, 3 sequence.

**Selectivity:** (60 dB/3 dB bandwidth ratio) < 15:1 for bandwidths 1 kHz to 3 MHz.

**Stability**

- Total Residual FM**
- Stabilized:** < 200 Hz p-p in 0.1 sec. .01—4.1 GHz.

**OPTION 400**

Permits operation on 48—440 Hz mains.

**All specifications identical to standard HP 8569B except:**

**Power requirements:** 48 to 440 Hz; 100, 120, 220 or 240 volts (-10% to +5%); 220 VA maximum. Fan cooled.

<sup>1</sup>Input level not to exceed +137 dB $\mu$ V damage level.

Table 1-2. HP Model 8569B Supplemental Characteristics (1 of 4)

**SUPPLEMENTAL CHARACTERISTICS**

**NOTE: Values in this table are not specifications but are typical characteristics included for user information.**

**FREQUENCY CHARACTERISTICS**

**FREQUENCY SPANS**

**1.7 to 22 GHz**

When this mode is selected the analyzer displays the entire spectrum from 1.7 to 22 GHz. A 3 MHz Resolution Bandwidth, 9 kHz Video Filter, and 100 msec/div Sweep Time are automatically selected.

**Full Band**

When selected by panel pushbutton, analyzer displays spectrum of Frequency Band chosen. This automatically selects a 3 MHz Resolution bandwidth and a 9 kHz Video Filter. Sweep Time/Div varies from approximately 10 msec to 100 msec/div depending on which Frequency Band is chosen. Tuning marker frequency (position) indicates where analyzer tuning will be centered if a Per Division span mode is chosen.

**Per Division**

In "F" position (full band), the entire range of the Frequency Band selected is spanned, thus allowing the use of Resolution Bandwidth and Video Filter settings other than those chosen when the Full Band pushbutton is depressed. Center frequency of the analyzer's display is set by the tuning control and indicated by the LED readouts. The Frequency CAL control to the right of the display window on the front panel is used to set the LED readout to agree with the actual center frequency of the CRT display (normally set using the 100 MHz CAL OUTPUT as a 0.100 GHz frequency reference).

**Out-of-range blanking**

The out-of-range portion of the CRT trace is automatically blanked whenever the analyzer is swept beyond a band edge.

**RESOLUTION**

**Bandwidth Ranges**

See Figure 1 for curves of typical analyzer resolution using different IF bandwidths.

**IF Bandwidth shape:**

Approximately gaussian (synchronously tuned, 4-pole filter)

**Frequency drift (fundamental mixing, .01-4.1 GHz) long term**

**At fixed center frequency after 1 hour warm-up:**

- Stabilized <math>\leq \pm 3.0 \text{ kHz}/10 \text{ minutes}</math>
- Unstabilized <math>\leq \pm 25 \text{ kHz}/10 \text{ minutes}</math>

**With Temperature Changes:**

- Stabilized <math>< 10 \text{ kHz}/^\circ\text{C}</math>
- Unstabilized <math>< 200 \text{ kHz}/^\circ\text{C}</math>
- Auto stabilizer may be disabled in narrow spans (<math>< 100 \text{ kHz}/\text{Div}</math>) by depressing front panel pushbutton switch to "OFF" position.

**VIDEO FILTER**

Video Filter bandwidths typically  $\pm 20\%$  of nominal value.

Post detection low-pass filter used to average displayed noise for a smooth trace. Nominal settings are given as decimal fractions of the Resolution Bandwidth: OFF, .3, .1, .03, .01, and .003. A 1 Hz NOISE AVG (noise averaging) setting is provided for noise level measurement.

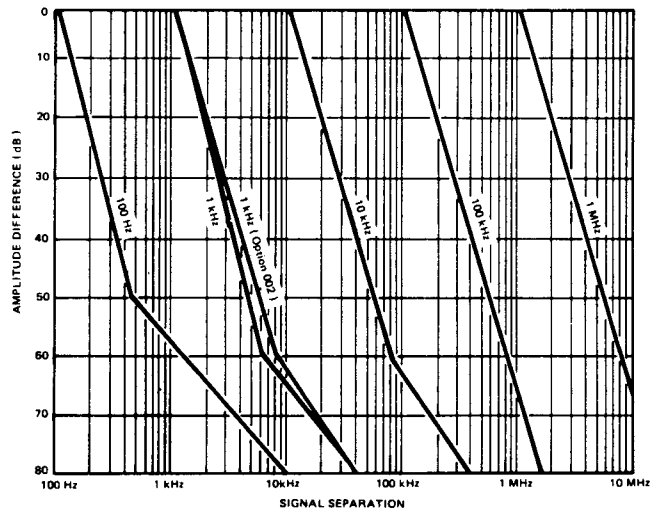

Figure 1. Typical Spectrum Analyzer Resolution

**INTERNAL PRESELECTOR**

Frequency Range	Description	Rejection
0.01 to 1.8 GHz	Low-pass filter	> 50 dB above 2.05 GHz
1.7 to 22 GHz	Tracking YIG tuned filter	> 70 dB greater than 642.8 MHz from center of pass band 1.7 to 18 GHz. > 60 dB from 18 to 22 GHz

**TRACKING PRESELECTOR**

**Preselector skirt roll-off:** Characteristics of a three-pole filter (nominally 18 dB/octave), 3 dB bandwidth typically varies from 25 MHz (at 1.7 GHz) to 70 MHz (at 22 GHz).

Table 1-2 HP Model 8569B Supplemental Characteristics (2 of 4)

**SUPPLEMENTAL CHARACTERISTICS**

**NOTE:** Values in this table are not specifications but are typical characteristics included for user information.

**AMPLITUDE CHARACTERISTICS**

**DYNAMIC RANGE**

Maximum power ratio of two signals simultaneously present at the input that may be measured within the limits of specified accuracy, sensitivity and distortion (i.e., spurious responses): 0.01 to 22 GHz > 70 dB.

**Spurious responses:** (Input attenuator set to 0 dB)

**Second harmonic distortion**

Frequency Range	Input Power	Relative Distortion
0.01 - 1.8 GHz	- 40 dBm	< - 70 dB
1.7 - 22 GHz	+ 30 dBm	< - 130 dB*

\*May be below average noise level

**Third order intermodulation**

Frequency Range	For Two Input Signals With		Relative Distortion
	Total Power	Signal Sep.	
0.01-22 GHz	- 30 dBm	≥ 50 kHz	< - 70 dB
1.7-12.9 GHz	- 10 dBm	≥ 70 MHz	< - 130 dB*
1.7-22 GHz	- 10 dBm	≥ 100 MHz	< - 130 dB*

\*May be below average noise level

For typical harmonic and third order intermodulation distortion, see Figure 2.

**Image and Multiple Responses:**

Frequency	Image (out of band)	Multiple (in-band)
0.01-1.8 GHz	< - 50 dB	non-existent
1.7-18 GHz	< - 70 dB	< - 70 dB
18-22 GHz	< - 60 dB	< - 60 dB

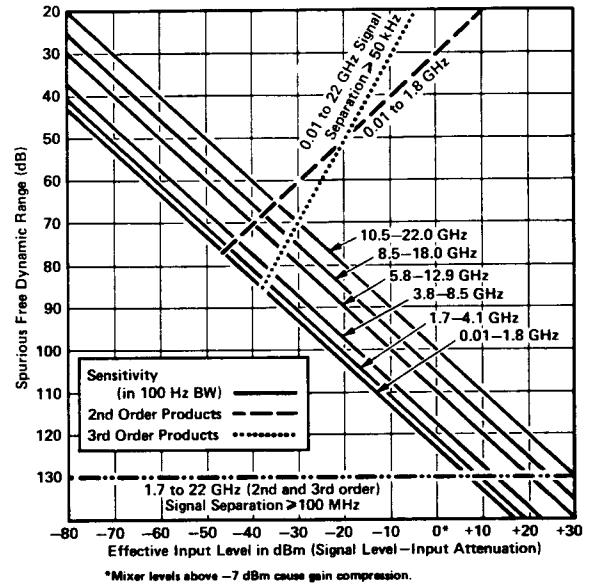

Figure 2. Optimum Dynamic Range Chart

**AMPLITUDE ACCURACY**

The overall amplitude accuracy of a measurement depends on an analyzer's performance and the measurement technique used. Applying IF substitution eliminates errors caused by the display, bandwidth gain variation, scale factor and input attenuator step size. Only IF gain variation (reference level change with input attenuation constant: < ±0.5 dB), calibrator amplitude (< ±0.3 dB), and frequency response remain. In brief, IF substitution minimizes error by minimizing control changes from the reference measurement (e.g., calibration).

For measurements in the Frequency Bands covering 1.7 to 22 GHz that don't require the best possible accuracy, the front panel preselector peak may be left centered in

Table 1-2. HP Model 8569B Supplemental Characteristics (3 of 4)

**SUPPLEMENTAL CHARACTERISTICS**

**NOTE: Values in this table are not specifications but are typical characteristics included for user information.**

its "green" setting. Best amplitude accuracy is obtained by peaking the preselector at the frequency of interest.

**Reference Level Variation (For any change of scale factor):**  $< \pm 1$  dB.

**FREQUENCY RESPONSE AND AVERAGE NOISE LEVEL**

For typical frequency response and average noise level versus input frequency, see Figure 3.

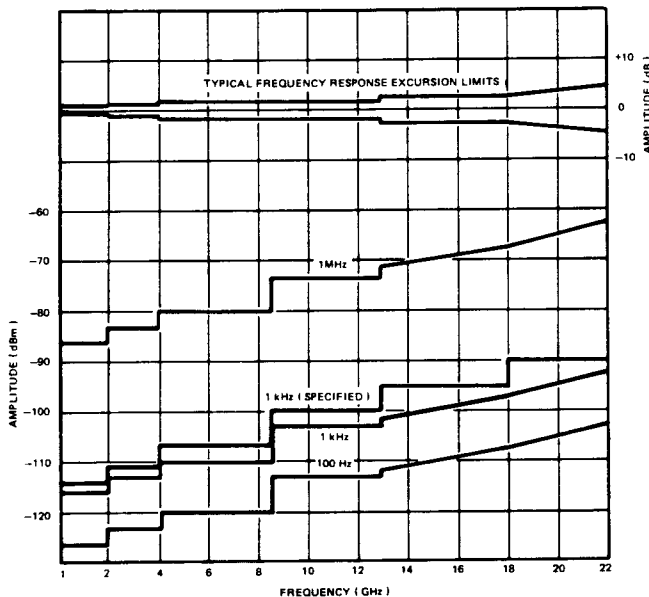

Figure 3. Typical Frequency Response and Average Noise Level Versus Input Frequency

**SIGNAL INPUT CHARACTERISTICS**

**INPUT 50Ω 0.01 TO 22 GHz**

**Input connector:** Precision type N female

**Input impedance**

**Input attenuator at 0 dB:** 50 ohms nominal

**SWR:**  $< 1.5$  0.01 to 1.8 GHz  
 $< 2.0$  1.7 to 22 GHz (at analyzer tuned frequency)

**Input attenuator at 10 dB or more:** 50 ohms nominal

**SWR:**  $< 1.3$  0.01 to 1.8 GHz  
 $< 2.0$  1.7 to 22 GHz

**LO Emission (2.00 to 4.46 GHz):**

$< -60$  dBm 0.01 to 1.8 GHz  
 $< -80$  dBm 1.7 to 22 GHz

**Input Protection (For input signals from .01 to 22 GHz)**  
 0.01 to 1.8 GHz Frequency Band: Internal diode limiter.

1.7 to 22 GHz Frequency Bands: Saturation of YIG filter (preselector) occurs at total input signal power levels below input mixer damage.

**EXTERNAL MIXING IF INPUT**

SMA female connector is a port for 321.4 MHz IF input signals and bias current. Internal gain adjustments have a range of 10 to 45 dB.

**SWEEP CHARACTERISTICS**

**SWEEP SOURCE**

**Manual:** Sweep determined by front panel control: continuously settable across CRT in either direction.

**External:** Sweep determined by 0 to +10V external signal applied to External Sweep input on rear panel. Blanking is controlled by signal at Blanking Input. Operation in Digital Storage Display mode with External sweep requires a Retrace signal input to rear panel Retrace input connector.

**Internal:** Sweep generated from internal sweep generator.

**SWEEP TRIGGER**

**Free Run:** Sweep triggered repetitively by internal source.

**Line:** Sweep triggered by power line frequency.

**Video:** Sweep internally triggered by detected waveform of input signal (signal amplitude of 0.5 division peak-to-peak required on CRT display).

**Trigger Level:** Sets the level of the sweep trigger signal, whether it is the displayed trace (Video mode) or an external trigger input (Ext mode).

**External Trigger:** Sweep triggering determined by signal input (between +1 and +10 volts) to rear panel BNC connector.

**Single:** Sweep triggered or reset by front panel Start/Reset pushbutton.

**Start/Reset:** Triggers sweep in Single sweep mode. Can also reset any internal sweep to left edge of display.

Table 1-2 HP Model 8569B Supplemental Characteristics (4 of 4)

## SUPPLEMENTAL CHARACTERISTICS

**NOTE:** Values in this table are not specifications but are typical characteristics included for user information.

### INPUT/OUTPUT CHARACTERISTICS

#### Plotter Interface

**Log:** <0.1 dB/dB, max error <1 dB

**Linear:** <0.1 division

**X, Y, and Z Axis Outputs:** These outputs are compatible with and may be used to drive all current HP XY recorders (using positive pencoils or TTL penlift input) and CRT monitors.

**Horizontal Sweep Output (X axis):** A voltage proportional to the horizontal sweep of the CRT trace which ranges from -5V for the left graticule edge to +5V for the right graticule edge. Output impedance is 5 kohms.

**Vertical Output (Y axis):** Detected video output proportional to vertical deflection of the CRT trace. Output increases 100 mV/div from 0 to 800 mV (from a 50 ohm source) for a full 8-division deflection. Output impedance is 50 ohms.

**Blank (Penlift or Z axis) Output:** A blanking output, 15V from 10 kohms, which occurs during CRT retrace or when sweeping beyond band edges. Otherwise output is low at 0V with a 10 ohm output impedance for a normal or unblanked trace (pen down).

**Blanking Input:** Permits remote Z axis control of CRT with TTL levels; normal <0.5V or open circuit, blank >2V. Input impedance is 10 kohms. Note that in Digital Storage mode, Blanking input does not directly blank the CRT; instead it sets blank bits in the trace memory so that the appropriate parts of the trace are blanked during the CRT refresh cycle.

**Caution:** maximum input is  $\pm 40V$ .

**External Sweep Input:** When the front panel Sweep Source switch is set to the EXT mode, a 0 to 10V ramp will sweep the analyzer through the frequency range determined by front panel Tuning and Frequency Span/Div controls. Input impedance is 100 kohms.

**Caution:** maximum input  $\pm 40V$ .

**Retrace Input:** Required for operation in Digital Storage Display mode if External Sweep is used. Normal level

<0.5V, blank (retrace) level >2V. Input impedance is 10 kohms.

**Caution:** maximum input is  $\pm 40V$ .

**External Trigger Input:** With the Sweep Trigger in EXT mode, a signal will trigger a sweep on the signal's positive slope between +1 and +10 volts according to the setting of the Trigger Level control. 100 kohms input impedance, dc coupled.

**Caution:** maximum input  $\pm 40V$ .

**21.4 MHz IF Output:** A 50 ohm, 21.4 MHz output linearly related to the RF input to the analyzer. Bandwidth controlled by the analyzer's Resolution Bandwidth setting; amplitude controlled by the Input Attenuator, IF gain vernier and first 6 IF Reference Level step gain positions (-10 through -60 dBm level with 0 dB input attenuation). Output is approximately -10 dBm from 50 ohms for full scale signals on the CRT.

**First LO Output:** Connector is SMA Female, 50 ohms. Terminate in a 50 ohm load when not in use.

**Frequency:** 2.00 to 4.46 GHz

**Power Level:** typically +8 dBm minimum

**Stability (Typical residual FM):**

Stabilized: 30 Hz p-p

Unstabilized: 2 kHz p-p

**External Mixing Bias:** -5 mA to +5 mA (into 500  $\Omega$ s) output from the EXT MIXING IF INPUT port. Maximum short circuit current limits:  $\pm 9$  mA, maximum open circuit voltage limits:  $\pm 3$  volts.

**Aux B:** Used during factory calibration.

### CATHODE RAY TUBE

**Type:** Post deflection accelerator, approximately 11.5 kV accelerating potential, aluminized P31 phosphor, electrostatic focus and deflection.

**Graticule:** Internal 8  $\times$  10 division. 1 division vertically is 1 centimeter, 1 division horizontally is 1.2 centimeters. There are 5 subdivisions per each major division.

**Annotation:** Major control settings are annotated on CRT.

**Viewing Area:** Approximately 9.6 centimeters vertically by 11 centimeters horizontally (3.8 inches by 4.7 inches).

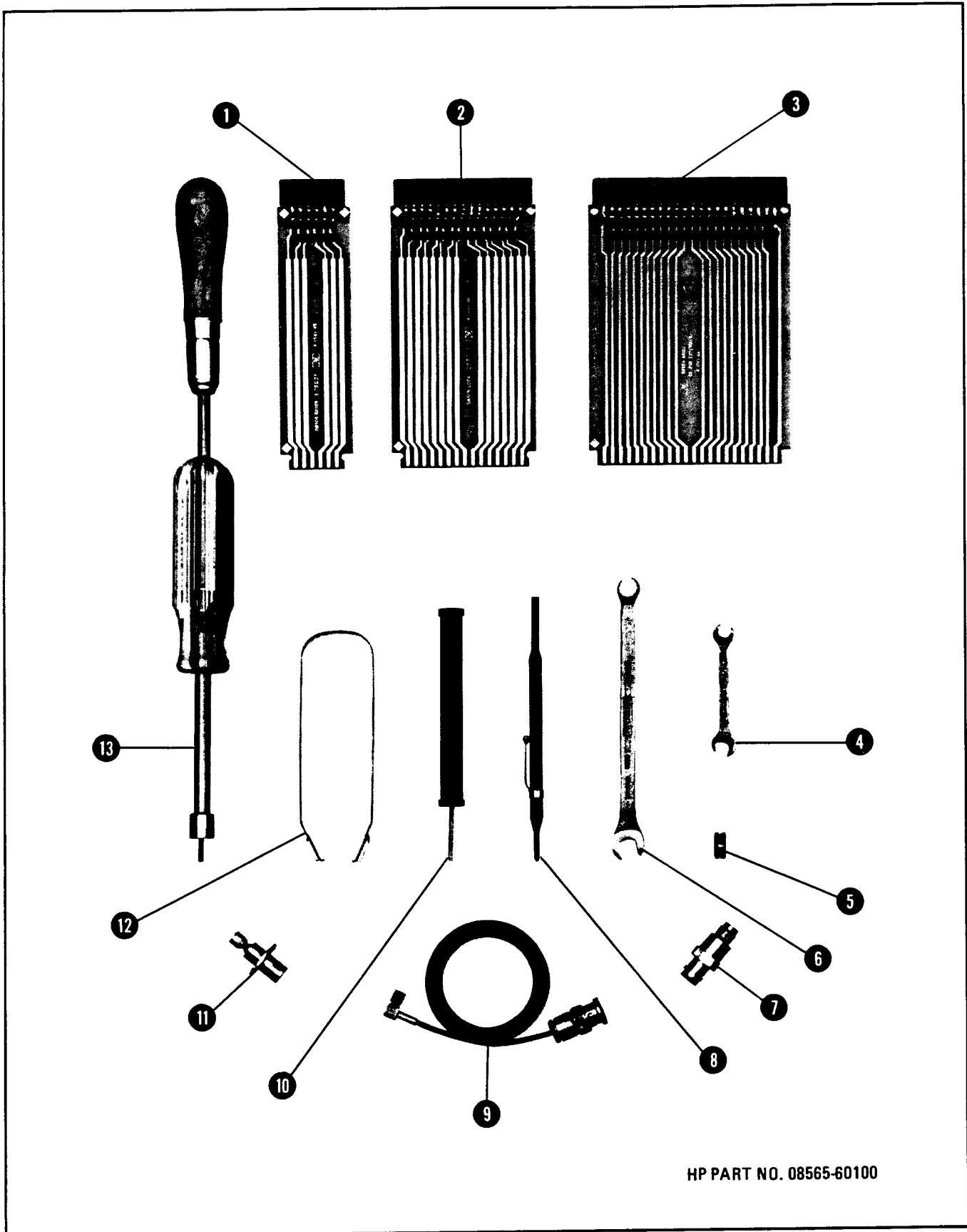
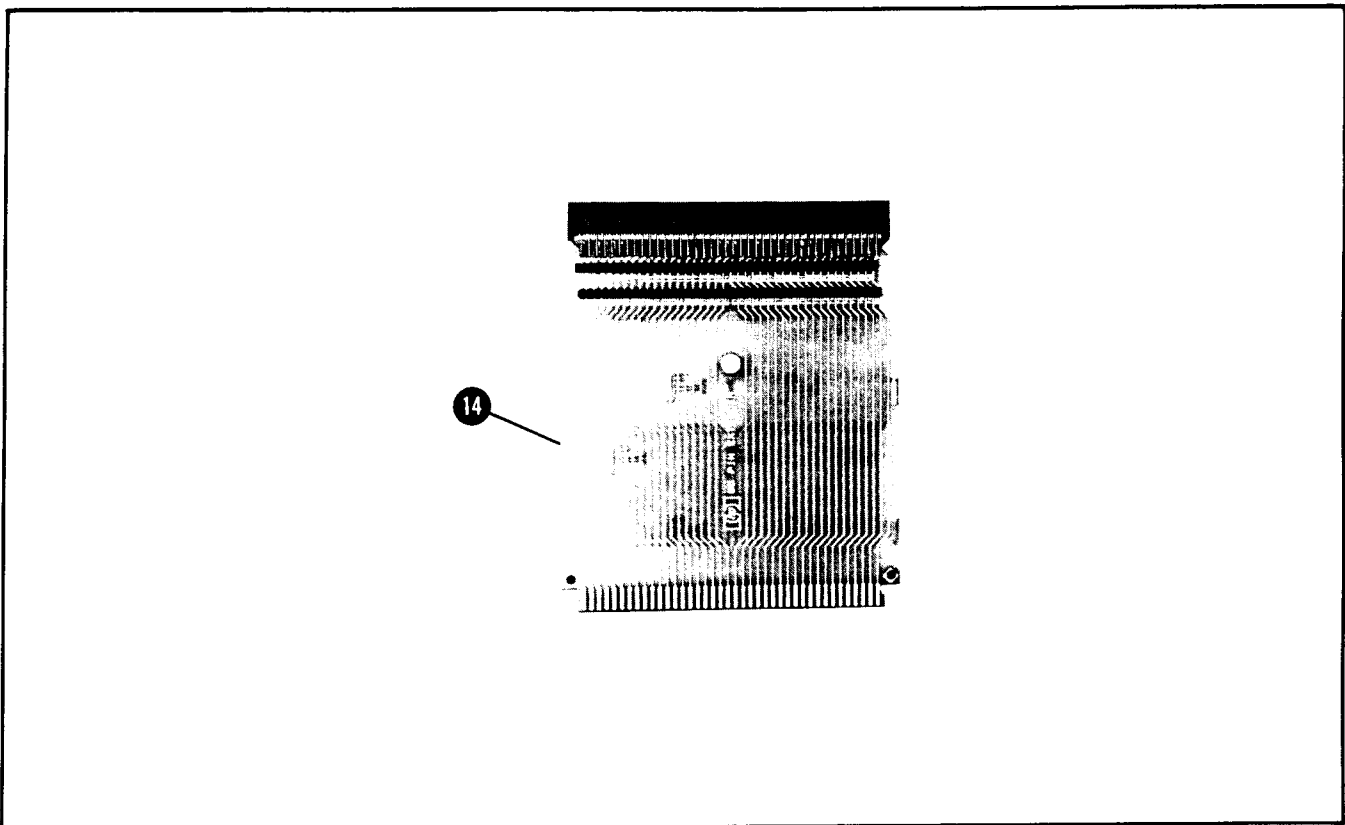

Figure 1-3. Service Accessories Package (1 of 2)





Item	Description	C D	HP Part Number
1	Extender board, 6 pin (12 conductors)	8	08505-60109
2	Extender board, 15 pin (30 conductors)	7	08505-60041
3	Extender board, 22 pin (44 conductors)	8	08565-60107
4	Wrench, 15/64 inch open end	8	8710-0946
5	Adapter, SMA male to male	3	1250-1158
6	Wrench, 5/16 inch slotted box end/open end	9	08555-20097
7	Adapter, BNC female to SMA male	6	1250-1200
8	Alignment tool	7	8710-0630
9	Test cable, subminiature (SMC) female to BNC male (36 inches long)	1	11592-60001
10	Alignment tool, non-metallic	4	8710-0033
11	Adapter, BNC female to SMC female (used to measure second LO output)	3	08565-60087
12	Connector extractor	6	8710-0580
13	Tuning tool (consists of modified 5/16 inch nut driver with modified No. 10 Allen driver)	6	08555-60107
14	Extender board, 40 pin (80 conductors)	9	08569-60013

Figure 1-3. Service Accessories Package (2 of 2)

Table 1-3. Recommended Test Equipment (1 of 3)

Instrument	Critical Specifications	Recommended Model	Use*
Digital Voltmeter	Range: -1000V to +1000V Accuracy: $\pm 0.004\%$ of reading plus 0.001% of range Input Impedance: 10 Meg ohms	HP 3455A	P,A,T
Oscilloscope	Frequency: 100 MHz	HP 1741A	A,T
Probe	10:1 Divider	HP 10004D	A,T
Probe	1:1 Divider	HP 10007D	A,T
Probe	High Voltage, 4 kV	HP 34111A	A,T
Function Generator	Amplitude: 0 to +10V p-p sine wave with dc offset Frequency: 1 to 5 kHz	HP 3312A	P,A,T
Comb Generator	Frequency Markers: 10 and 100 MHz Increments up to 5 GHz	HP 8406A	P,A
Signal Generator	Frequency: 50 to 500 MHz Modulation Frequency: 100 kHz Modulation Deviation: 1% of lowest frequency in range	HP 8640B, Opt. 001	P,A,T
Synthesized Signal Generator	Frequency Resolution: 2 Hz	HP 8662A	P
Frequency Counter	Range: .01 to 24.5 GHz	HP 5342A, Opt. 005	P,A,T
Electronic Counter	Time Interval Counter Function	HP 5300A/5302A	A
Power Meter	Range: -20 to +10 dBm	HP 435B	P,A,T
Power Meter	Recorder Output: 1V = full scale	HP 432A	A,T
Power Sensor	Frequency Range: .05 to 26.5 GHz	HP 8485A	P,A,T
Power Sensor	Frequency Range: 12.4-18.0 GHz	HP P486C	P,A,T
Power Sensor	Frequency Range: .01-18 GHz	HP 8481A, Opt. C03	P,A,T
Power Sensor	Frequency Range: 18.0-26.5 GHz	HP K486C	P,A,T
Spectrum Analyzer	Frequency: 300 MHz	HP 140T/8552B/8554B	A,T
Tracking Generator	Frequency: 300 MHz	HP 8444A, Opt. 059	A,T
Sweep Oscillator	Mainframe for RF Plug-in	HP 8350A	P,A,T

Table 1-3. Recommended Test Equipment (2 of 3)

Instrument	Critical Specifications	Recommended Model	Use*
Sweep Oscillator	Mainframe for RF Plug-in (Alternate for HP 8350A)	HP 8620C	P,A,T
RF Plug-in	Frequency: .01 to 26.5 GHz	HP 83595A	A,T
RF Plug-in	Frequency: .01 to 2.4 GHz	HP 86222A	P,A
RF Plug-in	Frequency: 2 to 22 GHz Residual FM: <30 kHz in 10 kHz Bandwidth	HP 86290A, Opt. H08	P,A,T
Synchronizer	No Substitute	HP 8709A, Opt. H10	A
DC Power Supply	4 to 6 volts dc (Floating)	HP 6214A	A
Termination	Frequency: dc to 18 GHz Impedance: 50 ohms Connector: Type N Male	HP 909A, Opt. 012	P
Mixer	Input Frequency: 23 GHz	HP 11517A, Opt. E03	P
Power Splitter	Frequency: 2 to 18 GHz Attenuation: 6 dB each arm Connectors: Type N Female Input APC-7 Outputs	HP 11667A, Opt. 002	P,A
Crystal Detector	Frequency: .1 to 22 GHz Input Connector: APC-3.5	HP 33330C	P,A,T
Attenuator	Attenuation: 10 dB $\pm$ 0.5 dB Frequency: .01 to 18 GHz Connectors: Type N	HP 8491B, Opt. 010	P,A
Attenuator	Frequency Range: 12.4–18 GHz	HP P382C	A
Step Attenuator	Attenuation: 0 to 12 dB in 1-dB steps Frequency: 100 MHz, Calibrated	HP 355C, Opt. H80	P,A
Attenuator	Frequency Range: 18.0–26.5 GHz	HP K382C	A
Step Attenuator	Attenuation: 0 to 120 dB in 10-dB steps Frequency: 100 MHz, Calibrated	HP 355D, Opt. H80	P,A
Adapter (2 required)**	Waveguide to SMA Jack	Narda 4608	P,A
Adapter	Type N Female to BNC Male	HP 1250-0077	P
Adapter (2 required)	Type N Male to BNC Female	HP 1250-0780	P,T
Adapter	Type N Plug to SMA Jack	HP 1250-1250	P,T

Table 1-3. Recommended Test Equipment (3 of 3)

Instrument	Critical Specifications	Recommended Model	Use*
Adapter**	BNC Female to SMC Female	HP 08565-60087	A,T
Adapter	K-Band to R-Band; for use with HP 11517A Mixer	HP 11519A	P
Adapter	APC-7 to Type N Female	HP 11524A	P,A
Adapter	APC-7 to Type N Male	HP 11525A	P,A
Adapter	APC-7 to SMA Female	HP 11534A	P,A
Adapter	Type N Female to SMA Female	HP 86290-60005	P,T
Adapter (2 required)	Type N Male to SMA Female	HP 1250-1404	P,T
Cable Assembly	SMA Plug both ends	HP 8120-1578	P,T
Cable Assembly	Type N Connector both ends	HP 11500A	P,T
BNC Short	Impedance: 50 ohms	HP 1250-0774	A
BNC Tee	Connectors: BNC Jack and Plug	HP 1250-0781	A
Test Cable**	SMA Female to BNC Male	HP 11592-60001	P
Diplexer	No Substitute	HP 5086-7721	
Directional Coupler	Frequency Range: 12.4–18.0 GHz	HP P752C	P,A
Directional Coupler	Frequency Range: 18.0–26.5 GHz	HP K752C	P,A

\*P = Performance Test; A = Adjustment; T = Troubleshooting  
\*\*These parts are included in Service Accessories Package; HP Part Number 08565-60100  
\*\*\*Only one required if HP 86290A, Opt. H08 used

## SECTION II INSTALLATION AND OPERATION VERIFICATION

### 2-1. INTRODUCTION

2-2. This section includes information about the initial inspection, preparation for use, storage and shipment, and operation verification for the HP Model 8569B.

### 2-3. INITIAL INSPECTION

2-4. Inspect the shipping container for damage. If the shipping container or cushioning material is damaged, it should be kept until the contents of the shipment have been checked for completeness and the instrument has been checked mechanically and electrically. The contents of the shipment should be as shown in Figure 1-1. The electrical performance is checked by the operation verification procedure in this section. If the contents are incomplete, if there is mechanical damage or defect, or if the instrument does not pass the operation verification test, notify the nearest Hewlett-Packard office. Keep the shipping materials for inspection by the carrier. The HP office will arrange for repair or replacement without waiting for a claim settlement.

### 2-5. PREPARATION FOR USE

#### 2-6. Power Requirements

2-7. The HP Model 8569B requires a power source of 100, 120, 220, or 240 Vac  $\pm 5\%$   $- 10\%$ , 48-66 Hz. Power consumption is less than 220 volt-amperes. The Option 400 permits operation on line frequencies of 50, 60, and 400 Hz at the voltages specified above.

#### 2-8. Line Voltage and Fuse Selection

#### WARNING

**BEFORE THIS INSTRUMENT IS TURNED ON, its protective earth terminals must be connected to the protective conductor of the main power cable. The main power cable plug shall be inserted only in a socket outlet that is provided with a protective**

**earth contact. DO NOT negate the earth-grounding protection by using an extension cable, a power cable, or an autotransformer without a protective ground conductor. Failure to ground the instrument properly can result in personal injury.**

#### CAUTION

**BEFORE TURNING ON THIS INSTRUMENT, make sure it is adapted to the voltage of the ac power source. The voltage selector card must be correctly set to adapt the HP Model 8569B to the power source. Failure to set the ac power input of the instrument for the correct voltage level could cause damage to the instrument when it is turned on.**

2-9. Select the line voltage and fuse as follows:

1. Measure the ac line voltage.
2. See Figure 2-1. At the power line module (rear panel), select the line voltage (100V, 120V, 220V, or 240V) closest to the voltage measured in step 1. Line voltage must be within  $+5\%$  or  $-10\%$  of the voltage setting. If it is not, use an autotransformer between the ac source and the instrument.
3. Make sure the correct fuse is installed in the fuse holder. The required fuse rating for each line voltage is indicated below the power line module.

#### 2-10. Cable Connections

**2-11. Power Cable.** In accordance with international safety standards, this instrument is equipped with a three-wire power cable. When connected to the appropriate power line outlet, this cable grounds the instrument cabinet. Table 2-1 shows the styles of plugs available on power cables supplied with HP instruments.

Table 2-1. AC Power Cables Available

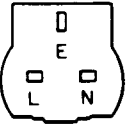
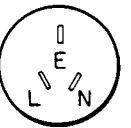
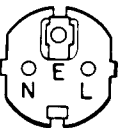
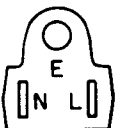
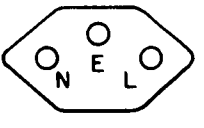
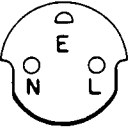
Plug Type,* AC Source End	Cable,* HP Part Number	C D	Plug Description, Instrument End	Length cm (inches)	Color	Country of Use
<p>250V</p>  <p>BS1363A</p>	8120-1351 8120-1703	0 6	Straight 90°	229 (90) 229 (90)	Mint Gray Mint Gray	United Kingdom, Cyprus, Nigeria, Rhodesia, Singapore, South Africa, India
<p>250V</p>  <p>NZSS198/ASC112</p>	8120-3169 8120-0696	0 4	Straight 90°	201 (79) 221 (87)	Gray Gray	Australia, New Zealand
<p>250V</p>  <p>CEE7-Y11</p>	8120-1689 8120-1692	7 2	Straight 90°	201 (79) 201 (79)	Mint Gray Mint Gray	East and West Europe, Saudi Arabia, Egypt, South Africa, India, (unpol- arized in many nations)
<p>125V</p>  <p>NEMA5-15P</p>	8120-1348 8120-1398 8120-1754 8120-1378 8120-1521 8120-1676	5 5 7 1 6 2	Straight 90° Straight Straight 90° Straight	293 (80) 203 (80) 91 (36) 203 (80) 203 (80) 91 (36)	Black Black Black Jade Gray Jade Gray Jade Gray	United States, Canada, Japan (100V or 200V), Mexico, Philip- pines, Taiwan
<p>250V</p>  <p>SEV1011 1959-24507 Type 12</p>	8120-2104	3	Straight	201 (79)	Gray	Switzerland
<p>220V</p>  <p>DHCK 107</p>	8120-1957 8120-2956	2 3	Straight 90°	201 (79) 201 (79)	Gray Gray	Denmark
<p>*Part number shown for source end plug is industry identifier for plug only. Number shown for cable is HP Part Number for complete cable including plugs. E = Earth Ground; L = Line; N = Neutral</p>						

**WARNING**

**If this instrument is to be energized through an autotransformer, make sure the common terminal of the autotransformer is connected to the protective earth contact of the power source outlet socket.**

**Any interruption of the protective ground, inside or outside the instrument, can make it a shock hazard.**

**2-12. Mating Connectors**

2-13. All mating connectors on the HP Model 8569B Spectrum Analyzer have standard Hewlett-Packard part numbers and are readily available.

**2-14. Operating Environment**

**2-15. Temperature.** The instrument may be operated in temperatures from 0°C to +55°C.

**2-16. Humidity.** The instrument may be operated in environments with humidity from 5% to 95% at 0°C to 40°C. However, the instrument should also be protected from temperature extremes that cause internal condensation.

**2-17. Altitude.** The instrument may be operated at altitudes up to 4572 meters (15,000 feet).

**2-18. Bench Operation**

2-19. The cabinet of the instrument has plastic feet and foldaway tilt stands for convenience in bench operation. The tilt stands raise the front of the instrument for easier viewing of the control panel. The plastic feet are shaped to make full width modular instruments self-aligning when stacked.

**2-20. Rack Mounting (Options 908 and 913)**

2-21. Instruments with Option 908 are shipped with a Rack Flange Kit, which supplies necessary hardware, with installation instructions, for mounting the instrument on a rack whose spacing is 482.6 mm (19 inches). Installation instructions are also given in Figure 2-2. See Table 2-2 for HP part numbers.

2-22. Instruments with Option 913 are shipped with a Rack Flange/Front Handle Kit, which supplies necessary hardware, with installation instructions, for the addition of front handles and mounting the instrument on a rack whose spacing is 482.6 mm (19 inches). Installation instructions are also given in Figure 2-2. See Table 2-2 for HP part numbers.

**2-23. Front Handles**

2-24. Instruments are shipped with a Front Handle Kit, which supplies necessary hardware, with installation instructions, for mounting front handles on the instrument. See Figure 2-2 for installation instructions.

*Table 2-2. Rack-Mounting Kits for HP 8569B*

Description	C D	HP Part Number	Quantity
<b>OPTION 908</b>			
Rack Flange	8	5020-8863	2
Machine Screw, Pan Head, 8-32 x 0.375 inch	7	2510-0193	8
<b>OPTION 913</b>			
Handle Assembly	0	5060-9900	2
Rack Flange	2	5020-8875	2
Machine Screw, Pan Head, 8-32 x 0.625 inch	8	2510-0194	8

RECEPTACLE FOR PRIMARY POWER CORD

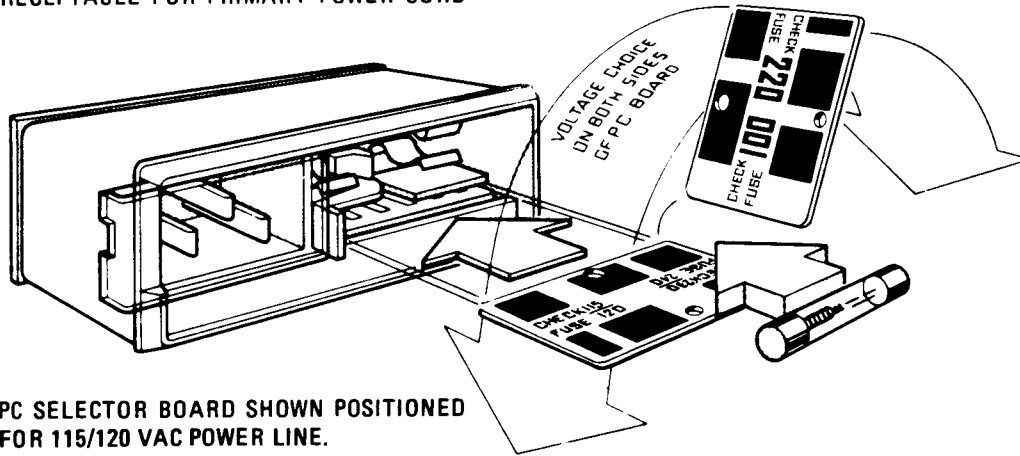

PC SELECTOR BOARD SHOWN POSITIONED FOR 115/120 VAC POWER LINE.

OPERATING VOLTAGE APPEARS IN MODULE WINDOW.

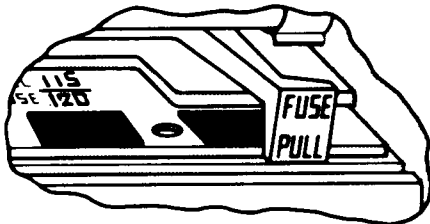

**SELECTION OF OPERATING VOLTAGE**

1. SLIDE OPEN POWER MODULE COVER DOOR AND PUSH FUSE-PULL LEVER TO LEFT TO REMOVE FUSE.
2. PULL OUT VOLTAGE-SELECTOR PC BOARD. POSITION PC BOARD SO THAT VOLTAGE NEAREST ACTUAL LINE VOLTAGE LEVEL WILL APPEAR IN MODULE WINDOW. PUSH BOARD BACK INTO ITS SLOT.
3. PUSH FUSE-PULL LEVER INTO ITS NORMAL RIGHT-HAND POSITION.
4. CHECK FUSE TO MAKE SURE IT IS OF CORRECT RATING AND TYPE FOR INPUT AC LINE VOLTAGE. FUSE RATINGS FOR DIFFERENT LINE VOLTAGES ARE INDICATED BELOW POWER MODULE.
5. INSERT CORRECT FUSE IN FUSEHOLDER.

*Figure 2-1. Line Voltage Selection with Power Module PC Board*



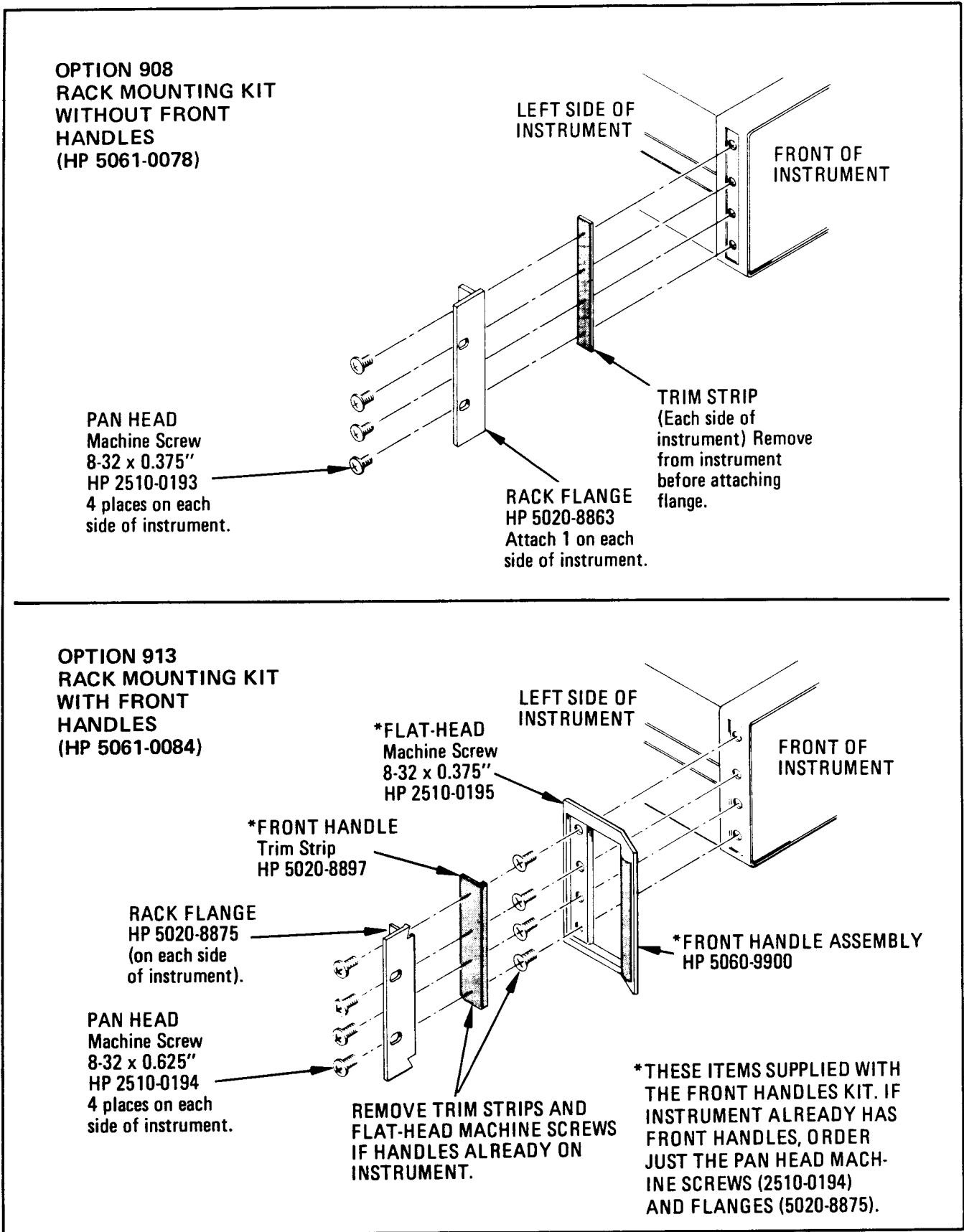
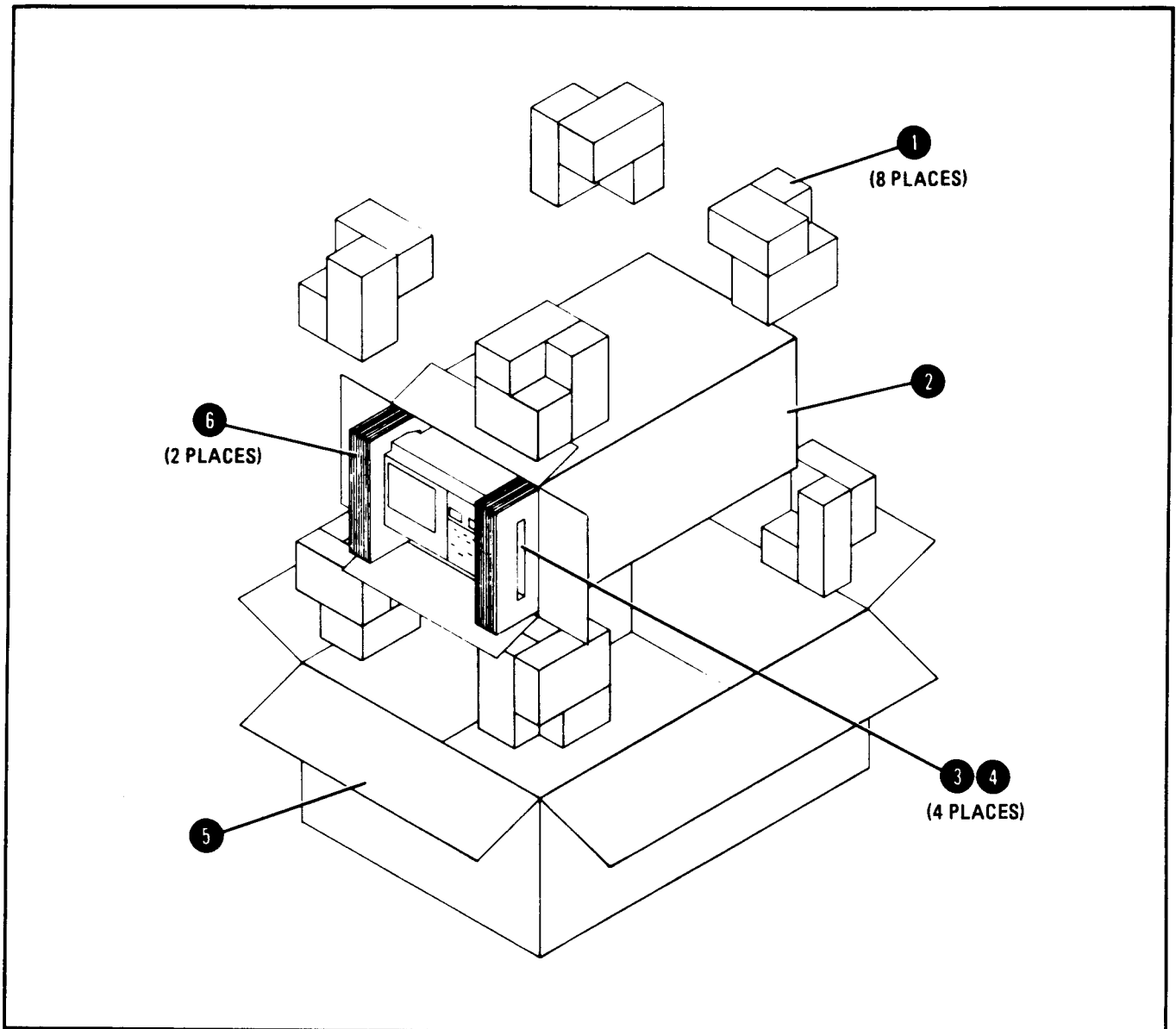

Figure 2-2. Attaching Rack Mounting Hardware and Handles



Item	Qty	C D	HP Part No.	Description
①	8	7	9220-2733	FOAM PADS—TOP CORNER; BOTTOM CORNER
②	1	4	9211-2622	CARTON—INNER
③	4	3	4040-1738	BARS—SHIPPING, PLASTIC
④	8	9	2510-0103	SCREW—FOR ATTACHING SHIPPING BARS (REMOVE HANDLES FOR SHIPMENT)
⑤	1	5	9211-2623	CARTON—OUTER
⑥	2	9	9220-2735	SIDE PADS, CORRUGATED CARDBOARD
	1	2	9222-0069	BAG, PLASTIC

Figure 2-3. Packaging for Shipment Using Factory Packaging Materials

**2-25. STORAGE AND SHIPMENT**

**2-26. Environment**

2-27. The instrument may be stored or shipped in environments within the following limits:

Temperature .....	- 40°C to + 75°C
Humidity .....	5% to 95% at 0°C to 40°C
Altitude .....	Up to 15,240 meters (50,000 feet)

The instrument should also be protected from temperature extremes that cause internal condensation.

**2-28. Packaging**

**2-29. Original Packaging.** Containers and materials identical to those used in factory packaging are available through Hewlett-Packard offices. Figure 2-3 illustrates the proper method of packaging the instrument for shipment using factory packaging materials. If the instrument is being returned to Hewlett-Packard for servicing, attach a tag indicating the type of service required, return address, model number, and full serial number. A supply of these tags is provided at the end of this section. Also mark the container FRAGILE to assure careful handling. In any correspondence, refer to the instrument by model number and full serial number.

**2-30. Other Packaging.** The following general instructions should be used for repackaging with commercially available materials:

1. Wrap the instrument in heavy paper or plastic. If shipping to a Hewlett-Packard office or service center, attach a tag indicating the type of

service required, return address, model number, and full serial number. A supply of these tags is provided at the end of this section.

2. Use a strong shipping container. A double-wall carton made of 350-pound test material is adequate.
3. Use enough shock-absorbing material (3-inch to 4-inch layer) around all sides of the instrument to provide firm cushion and prevent movement inside the container. Protect the control panel with cardboard.
4. Seal the shipping container securely.
5. Mark the shipping container FRAGILE to assure careful handling.

**2-31. OPERATION VERIFICATION**

2-32. The Operation Verification is designed to test only the most critical specifications and operating features of the instrument. It requires much less time and equipment than the complete performance tests listed in Section IV and is recommended for verification of overall instrument operation, either as part of incoming inspection or after repair. The Operation Verification consists of the following tests:

- Operational Check
- Tuning Accuracy
- Frequency Span Width with Resolution Bandwidth Accuracy
- Amplitude Accuracy

---

**OPERATION VERIFICATION**

---

**NOTE**

**Allow at least 30 minutes warm-up time.**

**EQUIPMENT:**

Frequency Counter .....	HP 5340A
Comb Generator .....	HP 8406A
Power Meter .....	HP 435B
Power Sensor .....	HP 8481A
Step Attenuator (10 dB/Step) .....	HP 355D

**NOTE**

**If substitution is necessary for any of the above listed equipment, the alternate models must meet or exceed the critical specifications listed in Table 1-3.**

**2-33. OPERATIONAL CHECK****PROCEDURE:**

1. Perform front-panel adjustment procedure provided on pull-out card.
2. Connect comb generator (100 MHz comb) to HP 8569B INPUT 50 $\Omega$  connector. Set all normal (green) settings, except set TRACE A and TRACE B to STORE BLANK. Set FREQUENCY SPAN/DIV to 1 MHz and TUNING to 0.100 GHz. Verify indication noted in Table 2-3 for each setting shown.

**NOTE**

**In checking some functions, first press CLEAR/RESET to clear digital trace from CRT display.**

---

**2-34. TUNING ACCURACY**
**SPECIFICATION:**

Overall tuning accuracy of the digital frequency readout in any span mode:

**Internal Mixing:**

$\pm$  (5 MHz or 0.2% of center frequency, whichever is greater, plus 20% of frequency span per division)

**DESCRIPTION:**

The tuning accuracy of the HP 8569B is verified by means of a comb generator at the first two FREQUENCY BAND GHz settings. The CAL OUTPUT frequency is measured, and the HP 8569B is calibrated at 100 MHz. The comb generator is then connected to the INPUT 50 $\Omega$  connector of the HP 8569B, and the tuning accuracy is checked.

---

**OPERATION VERIFICATION**

**2-34. TUNING ACCURACY (Cont'd)**

**PROCEDURE:**

1. Connect frequency counter to spectrum analyzer CAL OUTPUT as shown in Figure 2-4. Set all normal (green) settings, and other controls as follows:

TRACE A .....	WRITE
TRACE B .....	STORE BLANK
FREQUENCY BAND GHz .....	.01 - 1.8
TUNING .....	0.100 GHz
INPUT ATTEN .....	10 dB
REF LEVEL dBm .....	-10
REFERENCE LEVEL FINE .....	0
FREQUENCY SPAN/DIV .....	1 MHz
RESOLUTION BW .....	30 kHz
MIXING MODE .....	INT

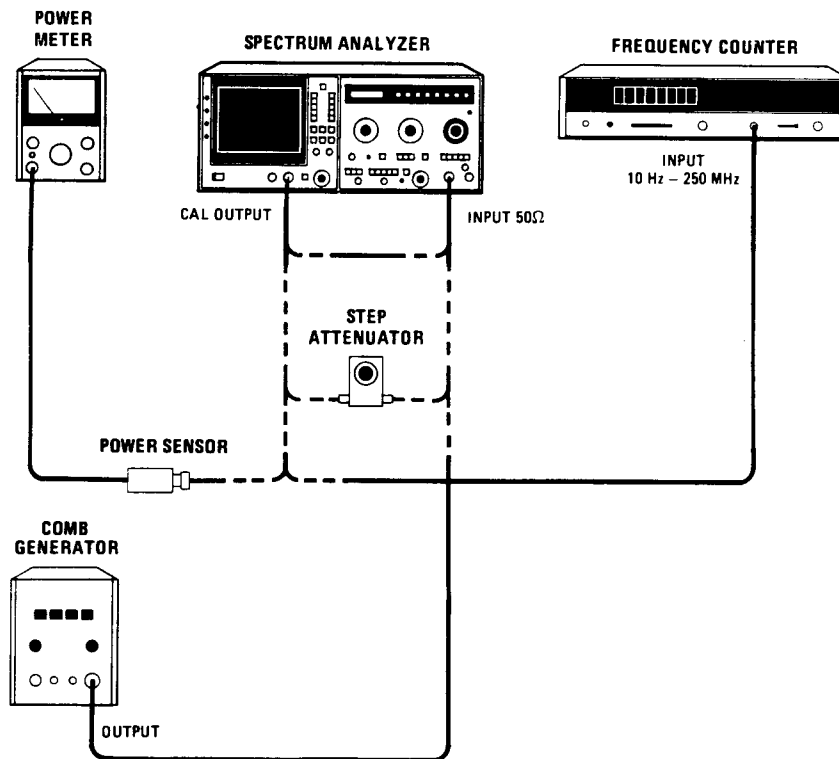

*Figure 2-4. Operation Verification Test Setup*

---

**OPERATION VERIFICATION**

---

**2-34. TUNING ACCURACY (Cont'd)**

2. Measure spectrum analyzer CAL OUTPUT frequency using frequency counter. Reading should be 100 MHz  $\pm$  0.01 MHz.
  3. Calibration of FREQUENCY GHz display is initially adjusted at 100 MHz. Connect CAL OUTPUT to INPUT 50 $\Omega$  and tune instrument to center signal on CRT display. FREQUENCY GHz readout should be 0.100. If necessary, adjust FREQ CAL screwdriver adjustment for 0.100 on FREQUENCY GHz display. Check that CTR annotation on CRT reads 100.0 MHz.
  4. Verify calibration of FREQUENCY GHz display in other frequency bands as follows:
    - a. Tune instrument for an indication of 1.800 GHz on FREQUENCY GHz digital readout.
    - b. Connect comb generator to spectrum analyzer INPUT 50 $\Omega$  and tune instrument to center 1.8 GHz comb tooth on CRT display. FREQUENCY GHz readout must be 1.800  $\pm$  0.005 GHz.
    - c. Select 1.7 – 4.1 FREQUENCY BAND GHz and set TUNING control for an indication of 3.000 GHz on FREQUENCY GHz readout.
    - d. Center 3.0 GHz comb tooth on CRT display. FREQUENCY GHz readout must be 3.000  $\pm$  0.006 GHz.
    - e. Set TUNING control for an indication of 4.000 GHz on FREQUENCY GHz readout.
    - f. Center 4.0 GHz comb tooth on CRT display. FREQUENCY GHz readout must be 4.000  $\pm$  0.008 GHz.
- 

**2-35. FREQUENCY SPAN WIDTH AND RESOLUTION BANDWIDTH ACCURACY****SPECIFICATION:**

Span width accuracy: The frequency error for any two points on the display for spans from 500 MHz to 20 kHz/Div (unstabilized) is less than  $\pm$  5% of the indicated separation; for stabilized spans 100 kHz/Div and less, the error is less than  $\pm$  15%.

Resolution bandwidth accuracy: Individual resolution bandwidth 3 dB points:  $< \pm$  15%.

**DESCRIPTION:**

A comb generator is used to check the span width and the CAL OUTPUT signal is used to check resolution bandwidth accuracy at different positions of the FREQUENCY SPAN/DIV and RESOLUTION BW controls. By verifying the calibration of these controls, proper operation of the sweep circuits is also verified.

**PROCEDURE:**

1. Connect comb generator to instrument INPUT 50 $\Omega$ .
-

**OPERATION VERIFICATION**

**2-35. FREQUENCY SPAN WIDTH AND RESOLUTION BANDWIDTH ACCURACY (Cont'd)**

- Set all normal (green) settings, and other controls as follows:

Spectrum Analyzer:

TRACE A ..... WRITE  
 TRACE B ..... STORE BLANK  
 FREQUENCY BAND GHz ..... .01 – 1.8  
 FREQUENCY SPAN/DIV ..... 100 MHz  
 RESOLUTION BW ..... 1 MHz (coupled)  
 INPUT ATTEN ..... 10 dB  
 REF LEVEL dBm ..... 0  
 TUNING ..... 0.500 GHz

Comb Generator:

Comb frequency ..... 100 MHz  
 Output amplitude ..... Optimum

- Tune spectrum analyzer to position one comb tooth at graticule reference line (far left).
- Note position of ninth spectral line (comb tooth). It must be on eighth graticule line  $\pm 0.4$  division. (See Figure 2-5.)
- Set FREQUENCY SPAN/DIV to 10 MHz (with RESOLUTION BW coupled) and comb generator to 10 MHz. Repeat steps 3 and 4.
- Set FREQUENCY SPAN/DIV to 1 MHz and comb generator to 1 MHz. Repeat steps 3 and 4.

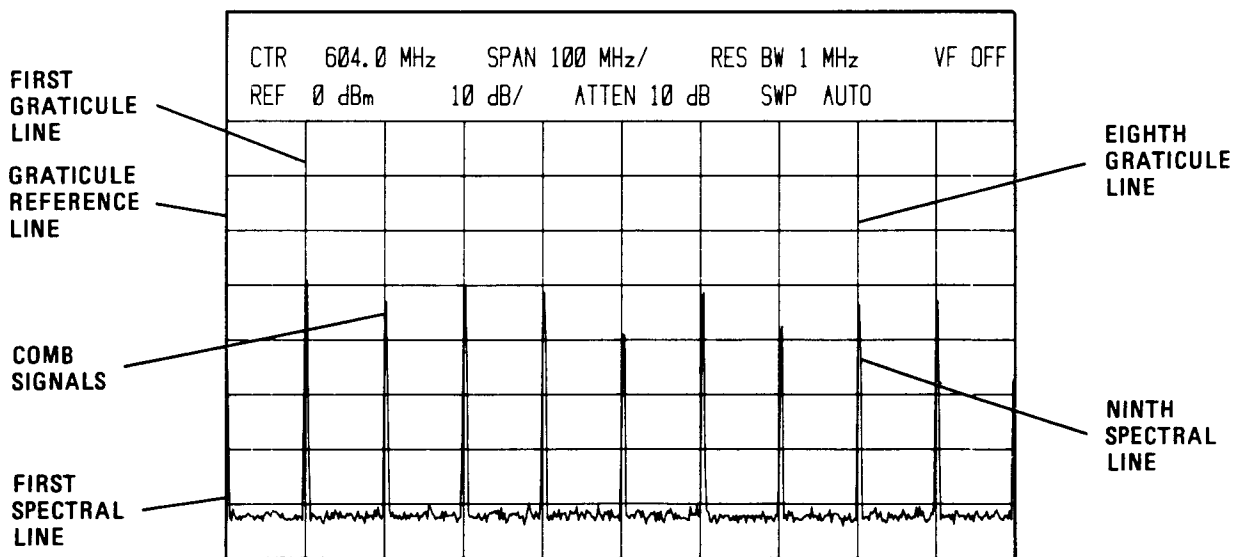

Figure 2-5. Span Width Accuracy Measurement

---

**OPERATION VERIFICATION**

---

**2-35. FREQUENCY SPAN WIDTH AND RESOLUTION BANDWIDTH ACCURACY (Cont'd)****NOTE**

**The wider FREQUENCY SPAN/DIV settings are checked using a comb generator. The narrow FREQUENCY SPAN/DIV settings are checked by observing RESOLUTION BW accuracy as follows:**

7. Set FREQUENCY SPAN/DIV to .2 MHz, RESOLUTION BW to 1 MHz, and AMPLITUDE SCALE to 1 dB.
8. Connect spectrum analyzer CAL OUTPUT to INPUT 50 $\Omega$  and tune spectrum analyzer to 0.100 GHz. Center signal on display and use REFERENCE LEVEL controls to position peak of signal to REFERENCE LEVEL line.
9. Note width of signal three divisions below REFERENCE LEVEL line. Specification: 5 divisions  $\pm 0.75$  division. Verification of the 1 MHz RESOLUTION BW setting verifies proper operation of the LC bandwidth filters.
10. Set FREQUENCY SPAN/DIV to 10 kHz and RESOLUTION BW to 30 kHz.
11. Repeat step 8 and note width of signal three divisions below REFERENCE LEVEL line. Specification: 3 divisions  $\pm 0.45$  division. Verification of the 30 kHz RESOLUTION BW setting verifies proper operation of the crystal bandwidth filters.

---

**2-36. AMPLITUDE ACCURACY****SPECIFICATIONS:**

Calibrator Output:  $-10 \text{ dBm} \pm 0.3 \text{ dB}$

Reference Level variation (Input Attenuator at 0 dB):

10 dB steps,  $+20^\circ\text{C}$  to  $+30^\circ\text{C}$ :

0 to  $-60 \text{ dBm}$ :  $< \pm 0.5 \text{ dB}$

0 to  $-90 \text{ dBm}$ :  $< \pm 1.0 \text{ dB}$

Vernier (0 to  $-12 \text{ dB}$ ) continuous:

Maximum error  $< \pm 0.5 \text{ dB}$ , when read from REFERENCE LEVEL FINE control.

Input Attenuator (at preselector input, 70 dB range in 10 dB steps):

Step size variation (for steps from 0 to 60 dB):

0 to 60 dB, 0.01 – 18 GHz:  $< \pm 1.0 \text{ dB}$

0 to 40 dB, 0.01 – 22 GHz:  $< \pm 1.5 \text{ dB}$

Maximum cumulative error:

0 to 60 dB, 0.01 – 18 GHz:  $< \pm 2.4 \text{ dB}$

0 to 40 dB, 0.01 – 22 GHz:  $< \pm 2.5 \text{ dB}$



---

**OPERATION VERIFICATION**

---

**2-36. AMPLITUDE ACCURACY (Cont'd)****PROCEDURE:**

1. Set all normal (green) settings, and other controls as follows:

FREQUENCY SPAN/DIV .....	1 MHz
RESOLUTION BW .....	30 kHz (coupled)
FREQUENCY BAND GHz .....	.01 – 1.8
TUNING .....	0.100 GHz
INPUT ATTEN .....	10 dB
REF LEVEL dBm .....	– 10
REFERENCE LEVEL FINE .....	0
AMPLITUDE SCALE .....	1 dB LOG/DIV

2. Measure CAL OUTPUT signal level with a power meter. Specification: – 10 dBm  $\pm$  0.3 dB.
3. Connect 100 MHz CAL OUTPUT signal through 355D step attenuator (set to 0 dB) to INPUT 50 $\Omega$  and tune spectrum analyzer to center signal on CRT display. Position peak of signal at REFERENCE LEVEL line with front-panel REF LEVEL CAL screwdriver adjustment.
4. To verify correct operation of the REFERENCE LEVEL FINE (Vernier) control, set 355D step attenuator to 10 dB. Set REFERENCE LEVEL FINE to –9. The peak of the signal on the CRT display should be one division below the REFERENCE LEVEL  $\pm$  0.5 division ( $< \pm$  0.5 dB). Return 355D step attenuator to 0 dB.
5. Set INPUT ATTEN to 70 dB, REF LEVEL dBm to 0, REFERENCE LEVEL FINE to – 8, RESOLUTION BW to 3 kHz, FREQUENCY SPAN/DIV to 1 kHz, and VIDEO FILTER to .03. Center signal on CRT display with TUNING control.
6. Adjust REF LEVEL CAL to position signal peak two divisions below REFERENCE LEVEL line.
7. Step instrument INPUT ATTEN from 70 to 0 dB while stepping 355D step attenuator from 0 to 70 dB (maintain a total attenuation of 70 dB). For each 10 dB step, the signal amplitude should not change more than  $\pm$  1 dB from the previous step. The total amplitude variation (difference between maximum and minimum signal levels over entire 70 dB range) should not exceed 2.4 dB.
8. Adjust REF LEVEL CAL to position signal peak two divisions below REFERENCE LEVEL line.
9. Step instrument REF LEVEL dBm from – 70 to – 10 while stepping 355D step attenuator from 70 dB to 10 dB (maintain signal level approximately two divisions below REFERENCE LEVEL line  $\pm$  0.5 division ( $\pm$  0.5 dB)).

## OPERATION VERIFICATION

*Table 2-3. Operational Check (1 of 3)*

Function	Setting	Indication
SWEEP SOURCE	MAN	Rotation of MANUAL SWEEP control varies position of trace on CRT display.
	EXT	No sweep. Bright dot on lower left edge of CRT display.
	INT	Sweep visible on CRT display.
SWEEP TRIGGER	LINE	Sweep visible on CRT display.
	VIDEO	Presence of CRT sweep is dependent on TRIGGER LEVEL setting.
	EXT	No CRT trace is visible.
	SINGLE	One sweep is triggered when START/RESET push-button is pressed.
	FREE RUN	Sweep visible on CRT display.
SWEEP TIME/DIV	Slowly rotate control counterclockwise.	Sweep on CRT display becomes increasingly slower.
	<p><b>NOTE</b></p> <p>Select 1.7–4.1 FREQUENCY BAND GHz and adjust TUNING control to center signal on CRT display.</p>	
PRESELECTOR PEAK	Rotate over full range.	Signal amplitude varies. (Set control for maximum signal amplitude.)
	<p><b>NOTE</b></p> <p>Set FREQUENCY SPAN/DIV to 100 kHz and adjust FINE tuning control to center signal on CRT display.</p>	
AUTO STABILIZER (Blue FREQUENCY SPAN/DIV settings)	OFF (in)	Tuning of signal with coarse TUNING control is continuous.
	ON (out)	Tuning of signal with coarse TUNING control causes signal to jump off CRT display.

Table 2-3. Operational Check (2 of 3)

Function	Setting	Indication
FREQUENCY SPAN MODE	<p align="center"><b>NOTE</b></p> <p align="center">Set TRACE A to WRITE and FREQUENCY SPAN/DIV to 100 MHz.</p>	
	PER DIV	Signals are displayed at one-division intervals.
	<p align="center"><b>NOTE</b></p> <p align="center">Set FREQUENCY SPAN/DIV to .2 MHz and adjust TUNING control to center signal on CRT display.</p>	
	ZERO SPAN	CRT trace is a straight line and FINE TUNING control affects signal amplitude.
	FULL BAND  1.7–22 GHz SPAN	Twenty-five comb teeth are visible and baseline marker position is determined by coarse TUNING control.  Baseline is displayed from left to right in five steps (see Section III). Return to PER DIV.
AMPLITUDE SCALE (Center signal on CRT display.)	10 dB (LOG/DIV)	10 dB change in REF LEVEL dBm changes signal amplitude by one division $\pm 0.1$ division.
	<p align="center"><b>NOTE</b></p> <p align="center">Set REF LEVEL dBm and REFERENCE LEVEL FINE to position signal peak 0.5 division below REFERENCE LEVEL graticule line. Center signal on CRT display with TUNING control.</p>	
	5 dB (LOG/DIV)	Signal peak one division below REFERENCE LEVEL graticule line ( $\pm 0.25$ division).
	2 dB (LOG/DIV)	Signal peak 2.5 divisions below REFERENCE LEVEL graticule line ( $\pm 0.6$ division).
	1 dB (LOG/DIV)  LIN	Signal peak 5 divisions below REFERENCE LEVEL graticule line ( $\pm 1.2$ divisions).  Signal peak 3.5 divisions below REFERENCE LEVEL graticule line ( $\pm 1.0$ division). Return to 10 dB.

## OPERATION VERIFICATION

Table 2-3. Operational Check (3 of 3)

Function	Setting	Indication
TRACE A	MAX HOLD  STORE VIEW	Increase and then decrease signal amplitude. Maximum signal is held on CRT display.  Trace is held on CRT display and is not affected by changes in control settings.
TRACE B	Set TRACE A to WRITE and repeat checks described for TRACE A.	
TRACES A and B STORE BLANK	Analog signal is displayed without CRT annotation.	
TRACES A and B STORE VIEW	Set TRACE A to WRITE, then to STORE BLANK. With TRACE B set to WRITE, vary signal amplitude or position, then set TRACE B to STORE VIEW. Set TRACE A to STORE VIEW. Both traces are displayed on CRT.	
<p><b>NOTE</b></p> <p>Set TRACE A to WRITE and TRACE B to STORE BLANK. Set FREQUENCY SPAN/DIV to 1 MHz and RESOLUTION BW to 30 kHz. Center signal on CRT display with TUNING control.</p>		
SIG IDENT	Depressed	Two signals on CRT display. Signal identifier signal is two divisions to left of comb tooth and is also lower in amplitude.
CRT Annotation	TRACE A to WRITE	Control settings are displayed on CRT, and annotation changes as settings are changed.
VIDEO FILTER	Step through each switch position	Each step decreases baseline noise level and decreases sweep speed. Sweep speed increases when switching to NOISE AVG position, and CRT trace is virtually a straight line.

Table 2-4. Operation Verification Test Record

Hewlett-Packard Company Model 8569B		Tested by _____		
Serial Number _____		Date _____		
Para. No.	Test Description	Results		
		Min.	Actual	Max.
<b>2-34</b>	<b>Calibrator Output Accuracy</b>			
	2. 100 MHz	99.99	_____	100.01
<b>2-34.</b>	<b>Tuning Accuracy</b>			
	4b. 1.8 GHz	1.795	_____	1.805
	4d. 3.0 GHz	2.994	_____	3.006
	4f. 4.0 GHz	3.992	_____	4.008
<b>2-35.</b>	<b>Span Width Accuracy</b>			
	4. 100 MHz FREQUENCY SPAN/DIV	-0.4 div	_____	+0.4 div
	5. 10 MHz FREQUENCY SPAN/DIV	-0.4 div	_____	+0.4 div
	6. 1 MHz FREQUENCY SPAN/DIV	-0.4 div	_____	+0.4 div
<b>2-35.</b>	<b>Resolution Bandwidth Accuracy</b>			
	9. 1 MHz RESOLUTION BW	4.25 div	_____	5.75 div
	11. 30 kHz RESOLUTION BW	2.55 div	_____	3.45 div
<b>2-36.</b>	<b>Calibrator Output Power</b>			
	2. CAL OUTPUT Signal	-10.3 dBm	_____	-9.7 dBm
<b>2-36.</b>	<b>Vernier (0-12 dB)</b>			
	4. Vernier Accuracy	0.5 div	_____	1.5 div
<b>2-36.</b>	<b>Input Attenuator Accuracy</b>			
	7. Error Between Adjacent Settings		_____	±1.0 div
	8. Error Over 60 dB Range		_____	±2.4 div
<b>2-36.</b>	<b>Reference Level Variation</b>			
	9. Reference Level Variation in LOG, 0 to -60 dB		_____	±0.5 div

## SECTION III OPERATION

### 3-1. INTRODUCTION

3-2. This section is published separately as "8569B Spectrum Analyzer Operation," HP Part Number 08569-90034. It describes typical applications of signal analysis and provides detailed instructions for both local (front-panel) and remote (HP-IB) operation.

3-3. A table of contents is provided at the beginning of this section.

### 3-4. ROUTINE MAINTENANCE

#### 3-5. Fuses

3-6. The HP 8569B has nine fuses, eight of which are internal. Only the ac line fuse, located at the back of the instrument, may be replaced by the operator. The ac line cord should be disconnected from the power source, then the other end disconnected from the instrument. With the power cord removed, access the fuse compartment by sliding open the clear plastic cover on the power module. Remove the fuse by

pulling the lever inside the fuse compartment. Replace the blown fuse with a fuse of the correct rating and type for the ac line voltage selected. Fuse ratings for different voltages are indicated below the power module. Access to the other eight fuses requires removal of the covers of the instrument. The internal fuses should be replaced by a qualified service technician.

#### 3-7. Air Filter

3-8. Inspect the air filter frequently and, if necessary, remove and clean it. To clean the filter, wash it in warm water and detergent. Thoroughly dry the filter before reinstalling it.

3-9. Unrestricted air flow within the instrument lengthens component life. Keep the air filter clean.

#### 3-10. Calibration

3-11. Performance tests (Section IV) should be performed every six months to ensure that the instrument meets the specifications listed in Section I.



# **8569B SPECTRUM ANALYZER OPERATION**

**Copyright © 1982, HEWLETT-PACKARD COMPANY  
1424 FOUNTAIN GROVE PARKWAY, SANTA ROSA, CALIFORNIA, 95404, U.S.A.**

## CONTENTS

Chapter	Page	Chapter	Page
INTRODUCTION . . . . .	1	Electromagnetic Interference (EMI) . . . . .	31
Signal Analysis . . . . .	1	Swept-Frequency Response . . . . .	33
BASIC DESCRIPTION . . . . .	2	5 HP-IB REMOTE OPERATION . . . . .	35
1 OPERATING THE HP 8569B . . . . .	3	APPENDIX A . . . . .	38
Line Power On . . . . .	3	OPERATING PRECAUTIONS . . . . .	38
Front Panel Adjustment Procedure . . . . .	3	Low Impedance AC . . . . .	38
Getting Started . . . . .	4	DC Precautions . . . . .	38
2 FRONT PANEL OPERATION . . . . .	8	APPENDIX B . . . . .	39
Tuning . . . . .	8	THEORY OF OPERATION . . . . .	39
Frequency Span Mode . . . . .	8	System Description . . . . .	39
Resolution Bandwidth . . . . .	10	RF Section . . . . .	39
Reference Level . . . . .	10	Automatic Stabilization Section . . . . .	39
Digital Storage Display . . . . .	13	IF Section . . . . .	40
Traces . . . . .	13	Digital Storage Display . . . . .	40
Trace Memory . . . . .	14	Tuning Control Section . . . . .	40
Direct Plotter Output . . . . .	17	APPENDIX C . . . . .	43
3 SPECIAL TOPICS . . . . .	18	AMPLITUDE CONVERSIONS . . . . .	43
Maximum Dynamic Range . . . . .	18	Conversion Equations . . . . .	43
Improving Amplitude Measurement Accuracy . . . . .	22	APPENDIX D . . . . .	44
CRT Photography and X-Y Recording . . . . .	22	OPTION STATUS INTERFACE . . . . .	44
External Mixer Operation . . . . .	23	APPENDIX E . . . . .	45
4 TYPICAL MEASUREMENTS . . . . .	26	SYNTAX REFERENCE GUIDE . . . . .	45
Distortion . . . . .	26	APPENDIX F . . . . .	50
Modulation . . . . .	27	CONTROL GLOSSARY . . . . .	50
Noise . . . . .	31		



# INTRODUCTION

## SIGNAL ANALYSIS

The spectrum analyzer is a receiver that displays signals in the frequency domain. The CRT on the analyzer displays signal amplitude (A) on the vertical axis and frequency (f) on the horizontal axis. A method of visualizing how a spectrum analyzer views the frequency domain is to picture a tunable bandpass filter that scans the frequency axis (see Figure 1). At any instant in time, the analyzer views only the signal it is tuned to receive, rejecting all others. In this way, all the individual components

of a signal are viewed separately. In comparison, an oscilloscope displays the signals in the time domain, and the amplitude displayed represents the vector sum of all signal components.

The purpose of this section is to acquaint the reader with the operation of the HP Model 8569B Spectrum Analyzer. Rather than discussing specific topics in detail, the reader is referred to existing application notes, which may be obtained by contacting your local Hewlett-Packard Sales Office.

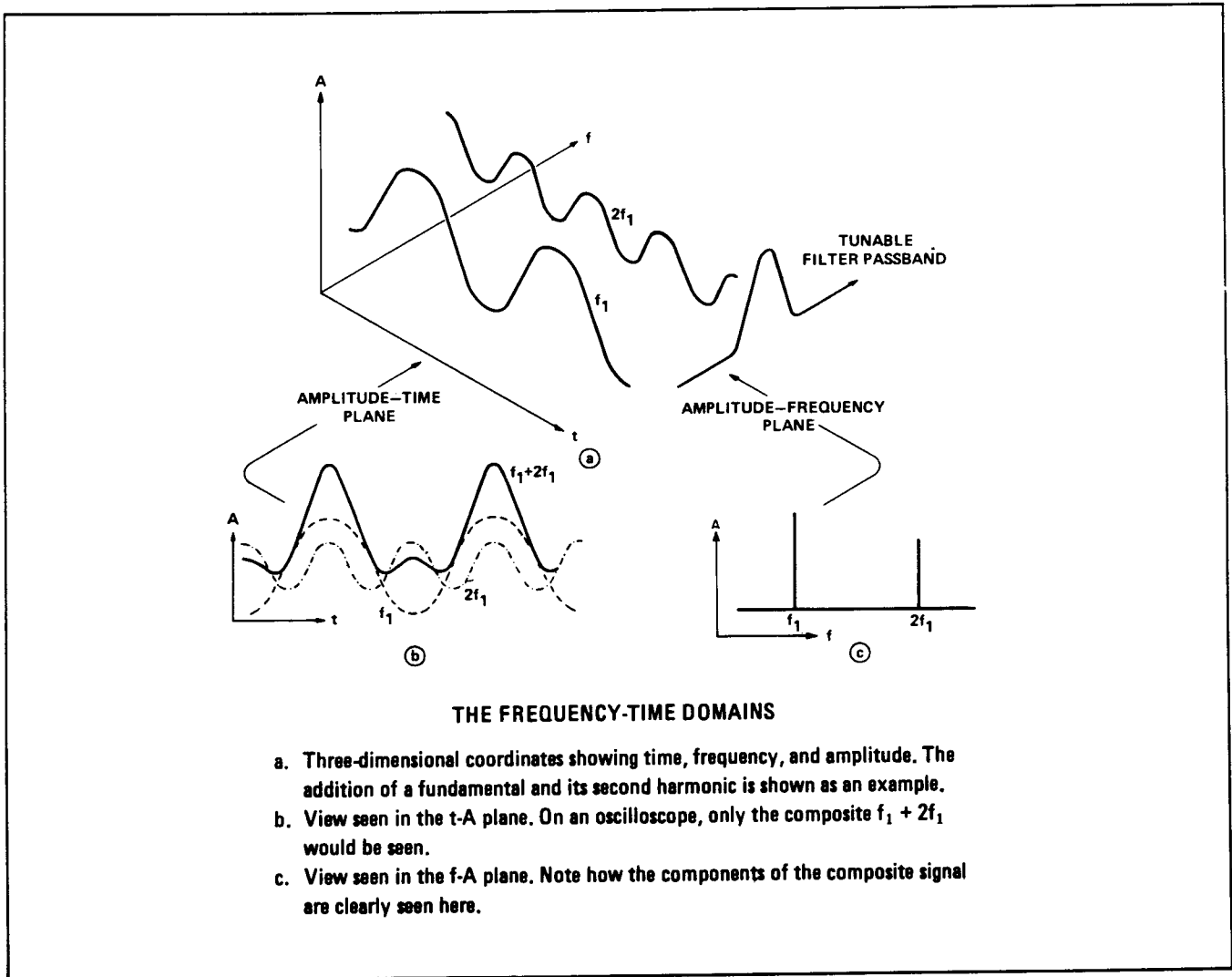

Figure 1. Frequency and Time Domain

## BASIC DESCRIPTION

The HP 8569B (Figure 2) is a high-performance spectrum analyzer designed for ease of use. Most measurements can be made with just three controls once the normal (green) settings are preset. The HP 8569B has absolute amplitude and frequency calibration from 0.01 to 22 GHz. The frequency span, bandwidth, and video filter are all coupled with automatic sweep to maintain a calibrated display and simplify use of the analyzer. Internal preselection eliminates most spurious responses to simplify signal identification. The preselector also extends the dynamic range of the analyzer and provides some protection for the input mixer.

The HP 8569B has a digital storage display system. All the information necessary to analyze a signal is displayed on the top portion of the CRT. The trace information for

both Trace A and Trace B resides in a digital storage buffer which is updated at the sweep rate of the analyzer. The information in this buffer is then displayed on the CRT and automatically refreshed at a flicker-free rate. Certain arithmetic and logical functions, such as digital averaging and normalization, can be performed on the trace values. The graticule, character, and trace information can be output directly to a digital plotter set for the listen only mode without the need for a controller. A controller connected via HP-IB may control the output or input of display information (e.g., trace values, text, control information).

The frequency range of the HP 8569B is 10 MHz to 22 GHz in direct coaxial input and 14.5 to 115 GHz when used with external mixers.

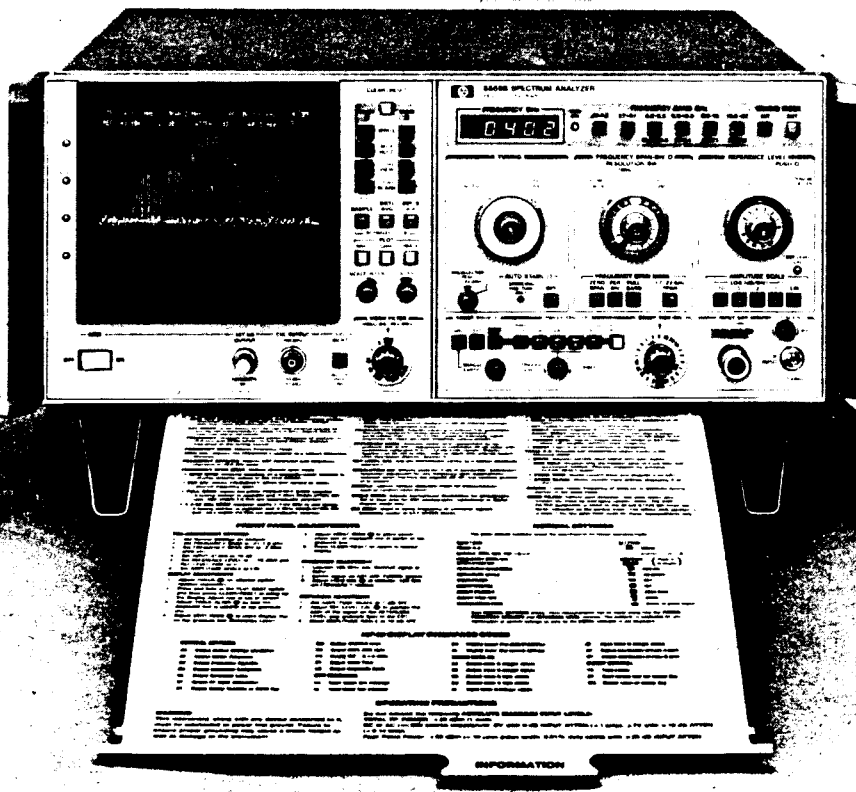

Figure 2. HP 8569B Spectrum Analyzer

# CHAPTER 1

## OPERATING THE HP 8569B

### LINE POWER ON

**CAUTION**

Before connecting the line power cord, make sure the proper line voltage and line fuse have been selected for the instrument. For complete information on power cords, voltage and fuse selection, refer to the HP 8569B Operation and Service Manual, Section II.

When LINE is switched ON, the instrument performs an automatic internal instrument check. This routine checks the operation of the system memory (RAM), system program memory (ROM), and the stroke memory (RAM), located in the analyzer's display section. If the test routine fails partially or if the routine will not run at all, refer to the HP 8569B Operation and Service Manual, Sections V and VIII.

Contained in the HP 8569B program memory (firmware) is a series of test patterns which aid in troubleshooting and in the adjustment of the analyzer. (Refer to HP 8569B Operation and Service Manual, Sections V and VIII.)

### FRONT PANEL ADJUSTMENT PROCEDURE

The front panel adjustment optimizes the performance of the HP 8569B Spectrum Analyzer to obtain its specified accuracy. The following step-by-step procedure is recommended for adjusting the HP 8569B. A condensed procedure is also located on a pull-out INFORMATION CARD attached to the analyzer.

#### Pre-adjustment Settings

1. Set normal (green) settings on analyzer (Table 1).
2. Set FREQUENCY BAND GHz to 0.01 – 1.8.
3. Set FREQUENCY SPAN/DIV to 1 MHz.
4. Set INPUT ATTEN to 10 dB.
5. Set REF LEVEL dBm to –10 and REFERENCE LEVEL FINE to 0 dB.

### Display Adjustments

1. Adjust FOCUS  $\odot$  for clearest control readout characters.
2. Press and hold in the  GRAT while pressing the  CLEAR/RESET to activate the Display Adjust line at top of screen as shown in Figure 3.

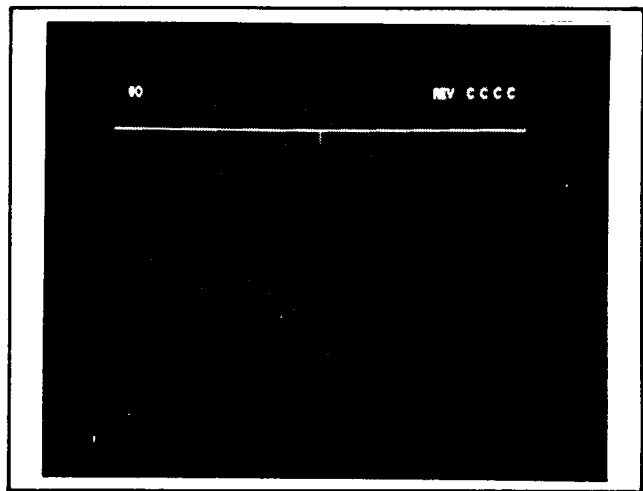

Figure 3. Display Line Adjustment

3. Adjust TRACE ALIGN  $\odot$  so that the displayed line is parallel to top graticule line.
4. Adjust VERT POSN  $\odot$  to place display line on top graticule line (REFERENCE LEVEL).
5. Adjust HORIZ POSN  $\odot$  to place center cross tick of displayed line at center of top graticule line.
6. Press  CLEAR/RESET to return normal display.

### Frequency Adjustment

1. Connect 100 MHz CAL OUTPUT signal to INPUT.
2. Center signal on CRT with TUNING control.
3. Uncouple the RESOLUTION BW and set it to 10 kHz.
4. Adjust FREQ CAL  $\odot$  to indicate 0.100 GHz on FREQUENCY GHz readout.

## Amplitude Adjustment

1. Center signal on CRT with TUNING control.
2. While keeping signal centered on the CRT, reduce FREQUENCY SPAN/DIV to 50 kHz.
3. Set AMPLITUDE SCALE to  1 dB .
4. Adjust REF LEVEL CAL  to position the peak of the signal on the REFERENCE LEVEL (top graticule line) of the CRT. Once the Front Panel Adjustment Procedure is completed, the CRT display should be similar to that shown in Figure 4.
5. Reset the AMPLITUDE SCALE to  10 dB .

The HP 8569B is now calibrated for absolute frequency and amplitude measurement.

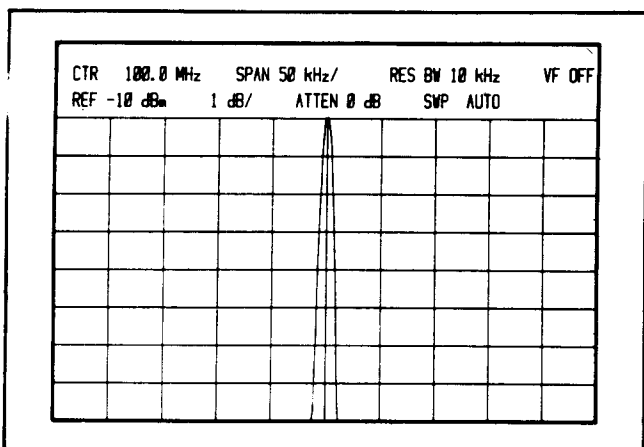

Figure 4. CAL OUTPUT Signal

## GETTING STARTED

The HP 8569B Spectrum Analyzer is a sensitive measuring instrument. To avoid damage to the instrument, do not exceed the following:

### Absolute Maximum Inputs:<sup>1</sup>

- Total RF Power: +30 dBm (1 watt)  
dc or ac (<<50 Ω source impedance):  
0V with 0 dB RF input attenuation (<: amp)  
±7V with ≥10 dB RF input attenuation (<0.14 amp).
- Peak Pulse Power:  
+50 dBm (<10 μsec pulse width, 0.01% duty cycle) with ≥20 dB INPUT ATTEN.

<sup>1</sup>For more detailed information regarding Operating Precautions refer to Appendix A.

## WARNING

This instrument and any device connected to it must be connected to power line ground. Failure to ensure proper grounding could cause a shock hazard to personnel or damage to the instrument.

## Normal Settings

The normal settings listed in Table 1 are used for the majority of measurements. For instance, 10 dB/division, INT sweep, and AUTO sweep time positions are most often used and so are classified as normal settings. All normal settings on the HP 8569B are colored green so the user can easily identify and set them initially.

Table 1. Normal Settings

Function	Setting
TRACE A, B	<input checked="" type="checkbox"/> WRITE
SAMPLE, DGTL AVG, INP-B→A	<input type="checkbox"/> OUT
FREQUENCY SPAN/DIV RESOLUTION BW	OPTIMUM (Push in to couple) <input checked="" type="checkbox"/>
FREQUENCY SPAN MODE	<input checked="" type="checkbox"/> PER DIV
MIXING MODE	<input checked="" type="checkbox"/> INT
AMPLITUDE SCALE	<input checked="" type="checkbox"/> 10 dB
VIDEO FILTER	<input type="checkbox"/> OFF
SWEEP SOURCE	<input checked="" type="checkbox"/> INT
SWEEP TRIGGER	<input checked="" type="checkbox"/> FREE RUN
SWEEP TIME/DIV	<input type="checkbox"/> AUTO
PRESELECTOR PEAK	<input type="checkbox"/> Center in green area

With normal settings, most measurements can be made using only the TUNING, FREQUENCY SPAN/DIV and REFERENCE LEVEL controls. The analyzer is calibrated for any combination of control settings as long as the UNCAL indicator is not displayed (refer to Chapter 2).

### Three-Knob Operation

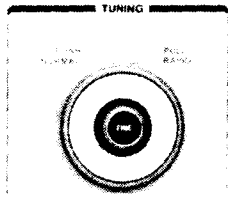

TUNING adjusts the center frequency of the analyzer. It also positions the marker in the full band and 1.7 to 22 GHz span modes.

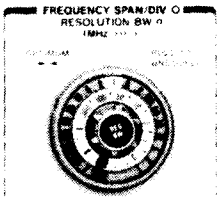

FREQUENCY SPAN/DIV sets the horizontal frequency calibration on the CRT. An optimum resolution bandwidth is automatically selected for a given frequency span when two arrows are aligned.

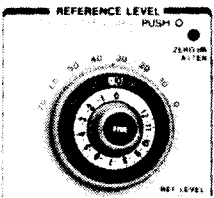

The REFERENCE LEVEL control sets the vertical amplitude calibration on the CRT. The REFERENCE LEVEL (top graticule line) on the CRT represents an absolute power level (in dBm or dBμV). Changes in RF INPUT ATTEN will also change the indicated REFERENCE LEVEL.

will also change the indicated REFERENCE LEVEL.

### Simplified Signal Analysis



The internal CAL OUTPUT signal is a convenient source to demonstrate how fast and easily the HP 8569B can measure frequency and amplitude.

Start by presetting the green normal settings listed in Table 1. This sets the analyzer in its normal, three-knob operation mode. Now connect the CAL OUTPUT signal to the INPUT connector of the analyzer and begin the measurement procedure:

1. Select the FREQUENCY BAND that includes the 100 MHz CAL OUTPUT signal (.01 – 1.8).

2. Use the TUNING control to tune the 100 MHz signal to the center of the display. The FREQUENCY SPAN/DIV control may be increased to facilitate tuning.
3. Adjust the FREQUENCY SPAN/DIV control to achieve the desired resolution. Since there is no modulation on the CAL OUTPUT signal, a 1 MHz/Div span is sufficient. Retune the signal to the center of the display if necessary.
4. Position the peak of the signal on the REFERENCE LEVEL (top graticule line) of the CRT using the REFERENCE LEVEL control.

Since the CAL OUTPUT signal is the calibration reference for the analyzer, FREQUENCY GHz should read 0.100 GHz and the REFERENCE LEVEL should read -10 dBm (Figure 5). If not, adjust the FREQ CAL and the REF LEVEL CAL to obtain the correct reading.<sup>2</sup>

For this next example, let us suppose that the microwave source in the test setup (Figure 6) operates in C-band (4 to

<sup>2</sup>A complete front panel adjustment procedure is included in this chapter.

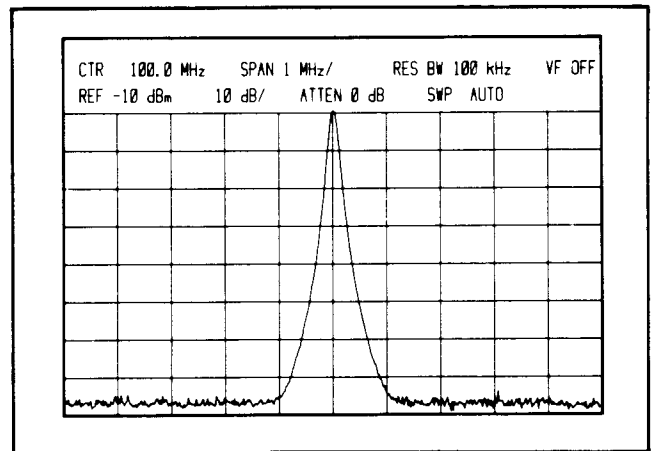

Figure 5. CAL OUTPUT Signal

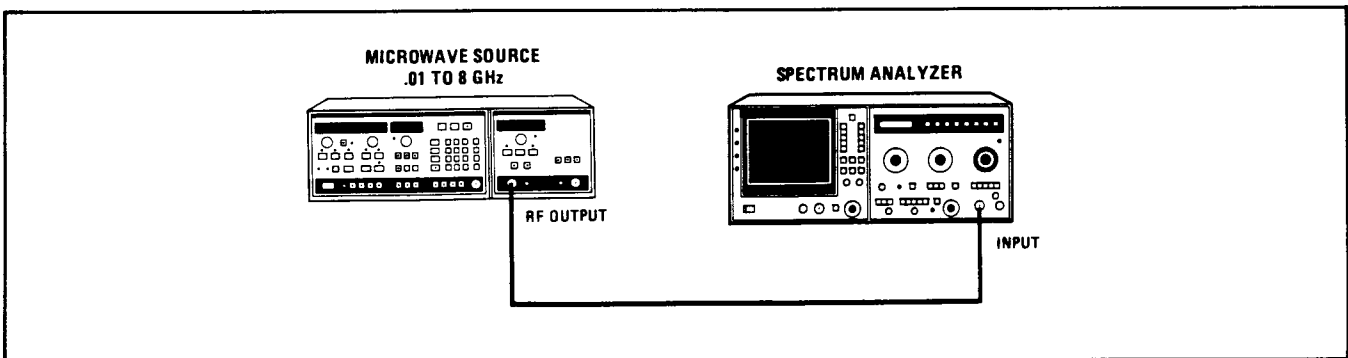

Figure 6. Microwave Source Test Setup

8 GHz). However, we do not know its exact output frequency. What, then, is the best way to locate a signal?

By using the full band feature of the HP 8569B, we can sweep an entire frequency band to search for a signal.

To view the microwave source in Figure 6 that operates in C-band, select the 3.8 to 8.5 GHz Frequency Band. Posi-

tion the tuning marker (which appears in the full band modes) under the signal to identify its frequency (Figure 7). Then by pushing the green PER DIV button, the signal at the marker will become the center frequency of the analyzer (Figure 8). In PER DIV mode, the desired frequency span can be adjusted with the FREQUENCY SPAN/DIV control. Figure 9 illustrates the procedure for locating a signal.

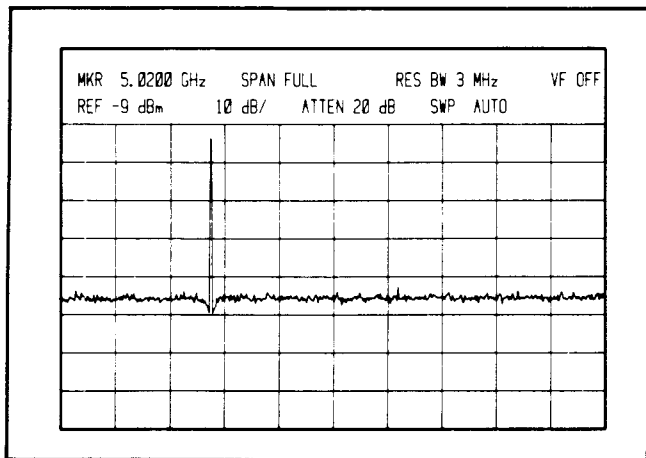

Figure 7. Tuning Marker in FULL BAND

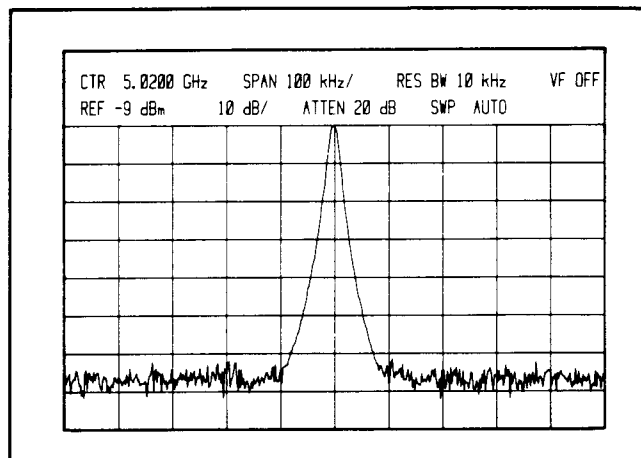
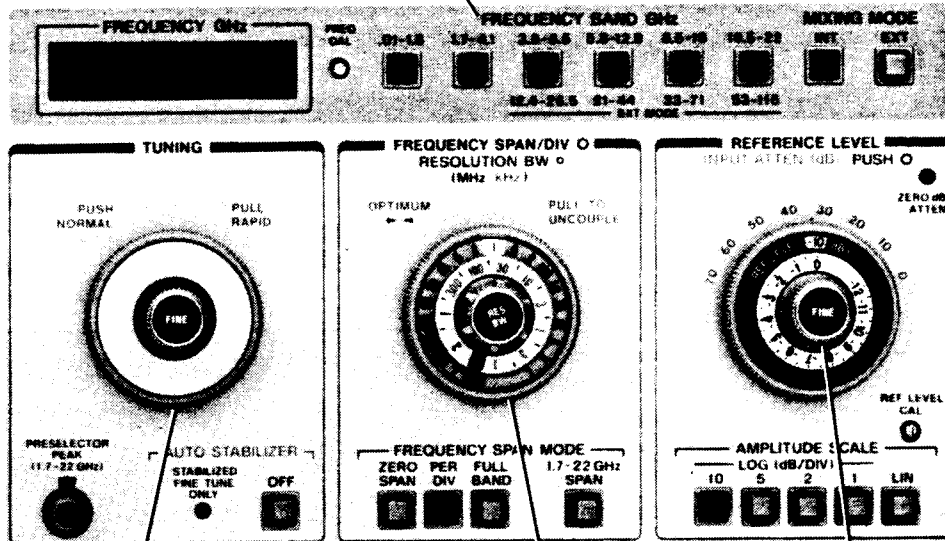

Figure 8. PER DIV Mode

**1** Set desired FREQUENCY BAND while in FULL BAND Frequency Span Mode



**2** TUNING Control sets marker which will be center frequency in PER DIV MODE

**3** Reset to PER DIV and adjust FREQUENCY SPAN/DIV

**4** Position signal on top REFERENCE LEVEL line

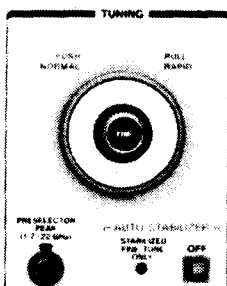

Figure 9. Locating a Signal

## CHAPTER 2 FRONT PANEL OPERATION

This chapter provides detailed descriptions of all front-panel controls. Following each description, the relevant HP-IB code is given. For additional HP-IB information, refer to Chapter 5 and Appendix E.

### TUNING



The TUNING control adjusts the center frequency of the analyzer. In the full-band modes, the TUNING control is used to locate an inverted marker on a particular signal. The FREQUENCY GHz readout on the front panel and the CTR readout on the display indicate the center frequency of the analyzer or the frequency at the

tuning marker. By pulling out the outer control, rapid tuning is enabled. Rapid tuning is especially useful when moving the tuning marker in full band modes. Normal tuning resumes when the knob is pushed in. When the analyzer is stabilized (frequency spans  $\leq 100$  kHz/Div), only FINE TUNING should be used to tune the analyzer. If coarse tuning is desired, the AUTO STABILIZER can be disabled with the push button switch.

#### HP-IB Code:

CF (output center frequency)

### FREQUENCY SPAN MODE



Four push button span modes are available on the HP 8569B: ZERO SPAN, PER DIV, FULL

BAND, and 1.7–22 GHz SPAN. An additional F (full-band) setting is available on the FREQUENCY SPAN/DIV control knob. The full-band modes (FULL BAND, F, and 1.7–22 GHz) enable the analyzer to monitor the various frequency bands or to provide multiband coverage from 1.7 to 22 GHz. PER DIV mode is generally used for detailed signal analysis, and ZERO SPAN is used for time domain analysis. The following text explains the various FREQUENCY SPAN MOD. settings in more detail.

#### HP-IB Code:

SP (output FREQUENCY SPAN/DIV)

### Zero Span

ZERO SPAN is used to recover the modulation on a carrier. In this mode, no sweep voltage is applied to the LO in the analyzer, so it operates as a manually tuned narrowband receiver. Carrier modulation is displayed in the time domain, and the calibrated SWEEP TIME/DIV control can be set manually to read the time variation of the signal. Selection of VIDEO trigger allows the sweep to be synchronized on the demodulated waveform. Figure 10 illustrates a demodulated AM carrier that was obtained with the analyzer in ZERO SPAN.

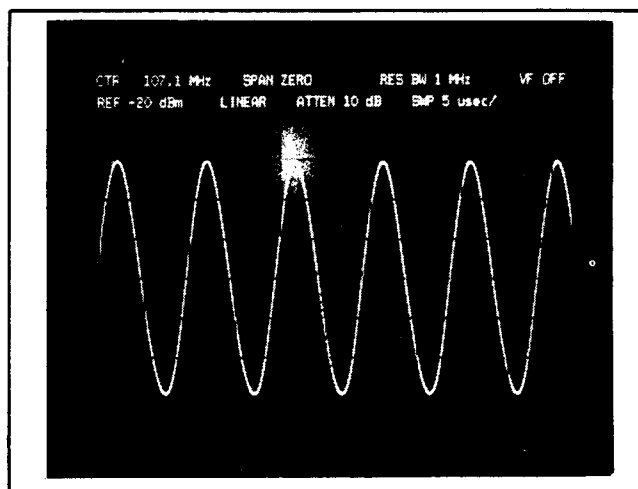

*Figure 10. AM Carrier Demodulated in ZERO SPAN*

Since the analyzer remains calibrated in ZERO SPAN, it is also possible to measure the amplitude and frequency of a CW signal. In this case, the CW signal appears as a horizontal line on the CRT. (See Figure 11.) Use a wide RESOLUTION BW setting and disable the AUTO STABILIZER for ease of tuning the signal.

The PER DIV mode enables the FREQUENCY SPAN/DIV control to set the horizontal frequency calibration of the CRT. The calibrated FREQUENCY SPAN/DIV control is adjustable from 1 kHz/Div to 500 MHz/Div in a 1, 2, 5 sequence of steps. An F (full-band) position allows the entire frequency band selected to be scanned. Normally, the RESOLUTION BW is coupled to the FREQUENCY SPAN/DIV so that the optimum RESOLUTION BW setting is automatically selected as the FREQUENCY SPAN/DIV is adjusted.



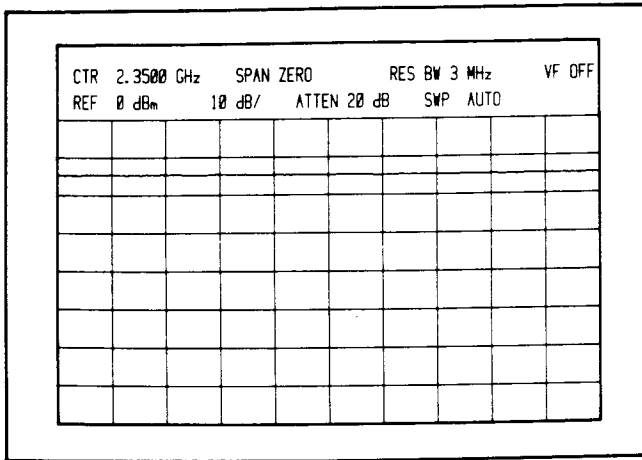

Figure 11. CW Measurement in ZERO SPAN

### Full Band

The FULL BAND mode scans in one sweep the entire selected frequency band. A tuning marker, 3 MHz RESOLUTION BW and 0.003 VIDEO FILTER are automatically set in FULL BAND mode. Different frequency bands can be selected to look for unknown signals. Once a signal is located in a particular frequency band, the tuning marker can be positioned under the signal to identify its frequency (Figure 12). Then, by pushing PER DIV, the signal that was at the marker will be displayed at the center frequency on the CRT (Figure 13). The F position on the FREQUENCY SPAN/DIV control differs from the FULL BAND push button in that it allows independent adjustment of the RESOLUTION BW and VIDEO FILTER controls.

### 1.7 – 22 GHz Span

A multiband sweep, available when the 1.7–22 GHz SPAN push button is depressed, is useful for observing signal activity within a broad frequency range. A tuning marker can be used with rapid tuning to quickly identify the frequency of any signal in the 1.7–22 GHz range. Figure 14 illustrates a typical display with the 1.7–22 GHz SPAN selected.

The stair-step baseline display in Figure 14 is the result of gain compensation applied to the higher frequency bands to maintain a calibrated amplitude display. Gain compensation is required because the higher frequency bands utilize higher LO harmonics of lower amplitude, yielding reduced sensitivity. To obtain the highest sensitivity from the analyzer, use the lowest FREQUENCY BAND GHz setting available when there is a frequency overlap. For instance, a 7 GHz signal can be measured in the 3.8 to 8.5 GHz band or the 5.8 to 12.9 GHz band. The sensitivity, however, is better in the 3.8 to 8.5 GHz band.

The five frequency span modes available on the HP 8569B provide the user with maximum flexibility in making measurements. Table 2 summarizes the characteristics of each FREQUENCY SPAN MODE setting.

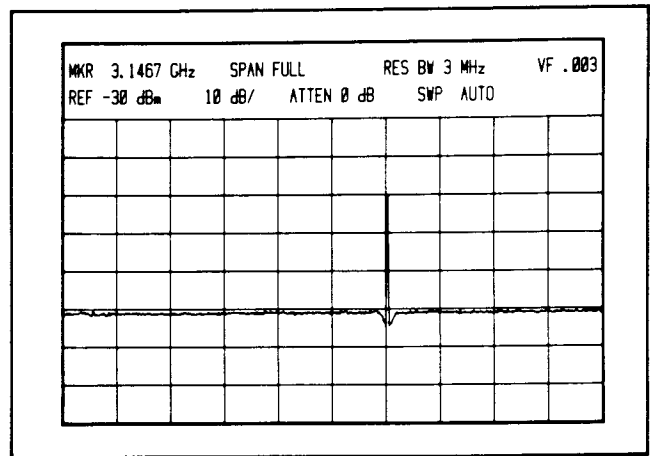

Figure 12. Identifying a Signal in FULL BAND

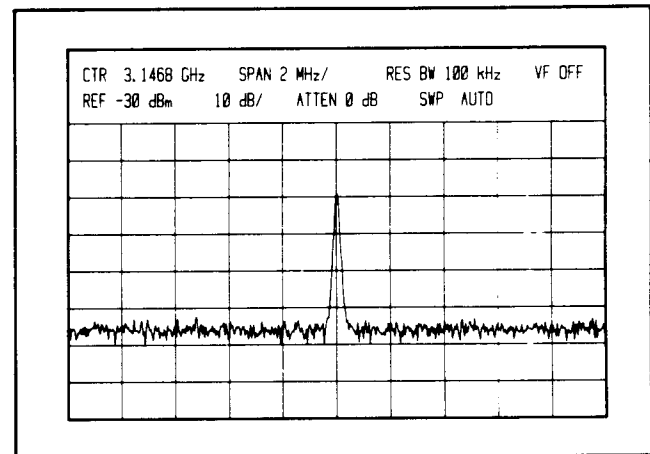

Figure 13. Analysis in PER DIV

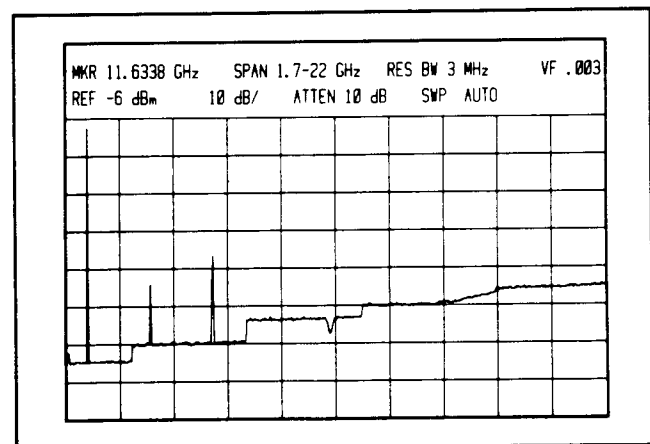
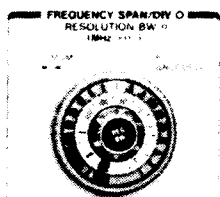

Figure 14. 1.7–22 GHz SPAN Mode

## RESOLUTION BANDWIDTH



In OPTIMUM setting, the RESOLUTION BW is coupled to the FREQUENCY SPAN/DIV by aligning the green markers and pushing the controls in. Once the controls are coupled at OPTIMUM, the best RESOLUTION

BW setting will be automatically chosen for any frequency span selected. The RESOLUTION BW control can also be coupled at a position other than OPTIMUM without loss of calibration of the spectrum analyzer. Calibration is always ensured when the UNCAL indication on the CRT annotation is not present.

For certain applications, independent control of the RESOLUTION BW control may be desirable. When either control knob is pulled out, the RESOLUTION BW control is decoupled, allowing different RESOLUTION BW settings to be selected. Figure 15 illustrates how an AM signal with 200 kHz sidebands is displayed at various RESOLUTION BW control settings. Note that the narrower resolution BW will yield increased sensitivity, since random noise decreases 10 dB for every reduction of Resolution BW by a factor of 10.

The SWEEP TIME/DIV control, when in AUTO position, will automatically select the proper sweep speed, whether the RESOLUTION BW control is coupled or uncoupled.

### HP-IB Code:

RB (output RESOLUTION BW)

## REFERENCE LEVEL

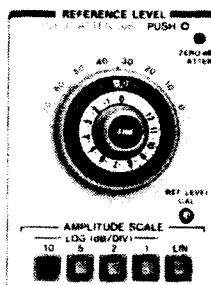

The main purpose of the REFERENCE LEVEL control is to set the absolute power at the REFERENCE LEVEL (top graticule line) on the CRT. When the peak of a signal is at the REFERENCE LEVEL, its absolute level (in dBm or dBμV) is indicated on the CRT annotation as well as on the REFERENCE LEVEL control knob.

This characteristic of the analyzer is used to improve the amplitude measurement accuracy using IF substitution (refer to Chapter 3).

The REFERENCE LEVEL control, combined with the INPUT ATTEN control, has a range of 172 dB; from -112 dBm to +60 dBm, as shown in Figure 16a. Although the REFERENCE LEVEL control is calibrated from +30 dBm to +60 dBm, signal levels should never exceed +30 dBm since that is the maximum power the analyzer can withstand without damage. In Figure 16b, the REFERENCE LEVEL control was adjusted to position the peak of  $f_1$  on the REFERENCE LEVEL line of the CRT. The absolute power of  $f_1$ , then, is +30 dBm. The level at  $f_1$  can be read from the calibrated CRT display as -20 dBm; that is, 50 dB below +30 dBm, assuming a 10 dB/Div Amplitude Scale factor. The Amplitude Scale factor can be set for 10 dB, 5 dB, 2 dB or 1 dB per division with respect to the REFERENCE LEVEL (top graticule line). The LIN scale factor sets the vertical calibration to volts with the bottom graticule line representing 0V. If desired, a low-level signal can be positioned at

Table 2. Frequency Span Modes

	Full Band Modes				
	ZERO SPAN <input type="checkbox"/> (Time Domain)	PER DIV <input checked="" type="checkbox"/> (Close Analysis)	<input checked="" type="checkbox"/> On Freq Span/Div Control	FULL BAND <input type="checkbox"/>	1.7-22 GHz SPAN <input type="checkbox"/>
TUNING MARKER	NO	NO	YES	YES	YES
FREQUENCY SPAN	ZERO (Manual Tune)	Selectable from 1 kHz/DIV to 500 MHz/DIV	Depends on FREQUENCY BAND selected	Depends on FREQUENCY BAND selected	1.7 to 22 GHz
RESOLUTION BANDWIDTH	Selectable	OPTIMUM <input checked="" type="checkbox"/> or Selectable	Selectable	Fixed at 3 MHz	Fixed at 3 MHz
VIDEO FILTER	Selectable	Selectable	Selectable	Fixed at 0.003 x 3 MHz = 9 kHz	Fixed at 0.003 x 3 MHz = 9 kHz

the REFERENCE LEVEL line to read its power level directly on the CRT annotation. The signal  $f_1$  in Figure 16c is positioned on the REFERENCE LEVEL line to read  $-80$  dBm directly.

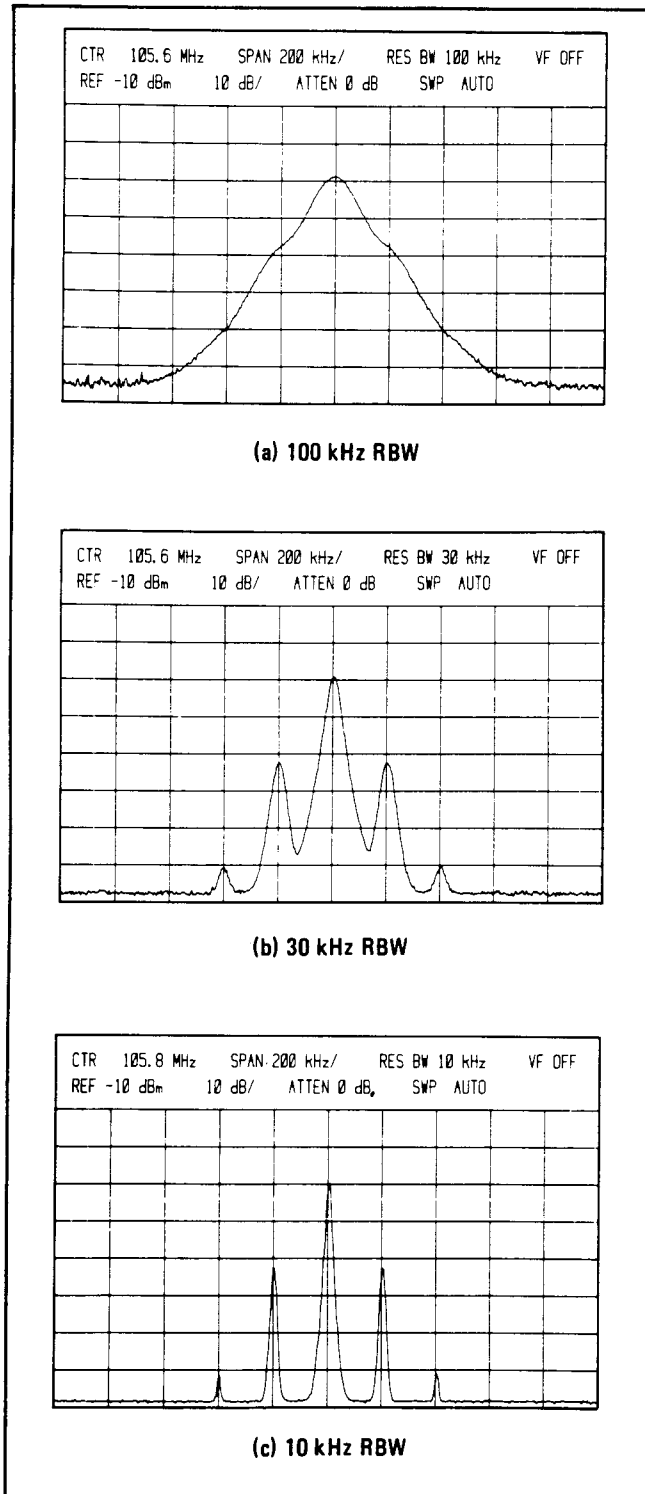
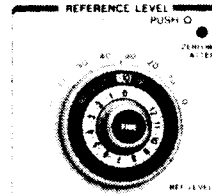

Figure 15. Resolving Modulation Sidebands

The REFERENCE LEVEL line on the CRT is determined by a combination of IF gain (REFERENCE LEVEL control) and RF attenuation (INPUT ATTEN). The outer control knob adjusts the IF gain in 10 dB steps. A fine vernier knob provides continuous control from 0 to  $-12$  dB.



Pushing in the outer knob allows selection of RF input attenuation (blue numbers) from 0 to 70 dB. A reminder light is lit whenever 0 dB INPUT ATTEN is selected. Except for noise measurements or when maximum sensitivity is required, a minimum INPUT ATTEN setting of 10 dB should always be used to ensure a good SWR and to minimize uncertainties due to mismatches.

#### HP-IB Code:

RL (output REFERENCE LEVEL)  
 LG (output AMPLITUDE SCALE)  
 AT (output RF INPUT ATTENUation)

#### Video Filter



The VIDEO FILTER control is useful for observation of a low-level signal that is close to the noise level. Figure 17 illustrates how use of the VIDEO FILTER control allows measurement of low-level signals, that are close to the noise level.

A NOISE AVG position on the VIDEO FILTER control allows the analyzer to perform noise level measurements or to measure its own sensitivity (for a given RESOLUTION BW setting). The NOISE AVG position engages a 1 Hz low-pass filter to average the noise displayed on the CRT. The sweep time of the analyzer increases to facilitate noise level measurements.<sup>3</sup> Another method of making noise and low-level signal measurements easily and accurately is to use  DGTL AVG (Digital Averaging) mode.

#### HP-IB Code:

VF (output VIDEO FILTER)

<sup>3</sup>Because of detector and log amplifier characteristics, 2.5 dB should be added to obtain the correct noise power reading. Refer to Hewlett-Packard Application Notes 150-4 and 150-9 for details.

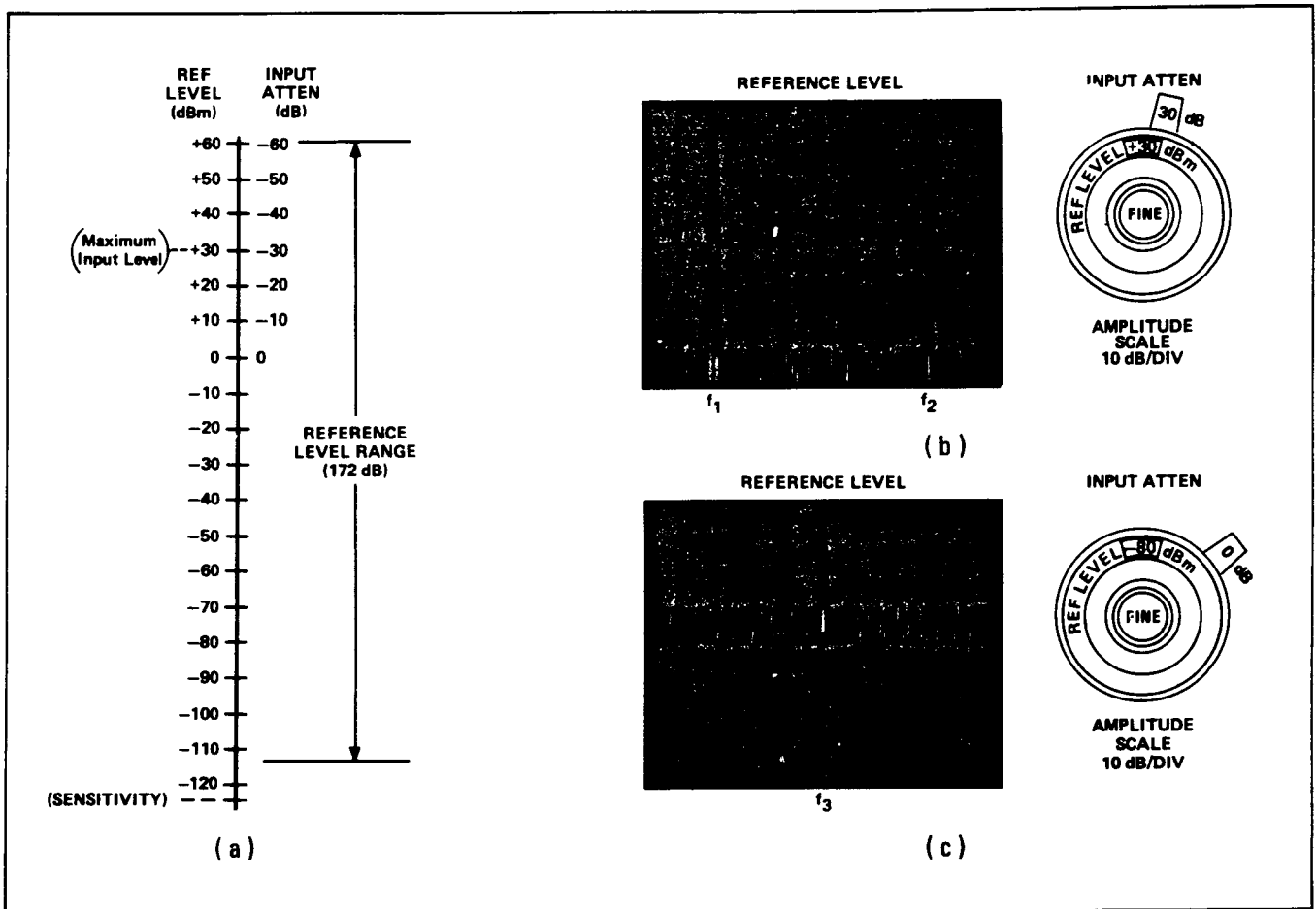

Figure 16. Reference Level

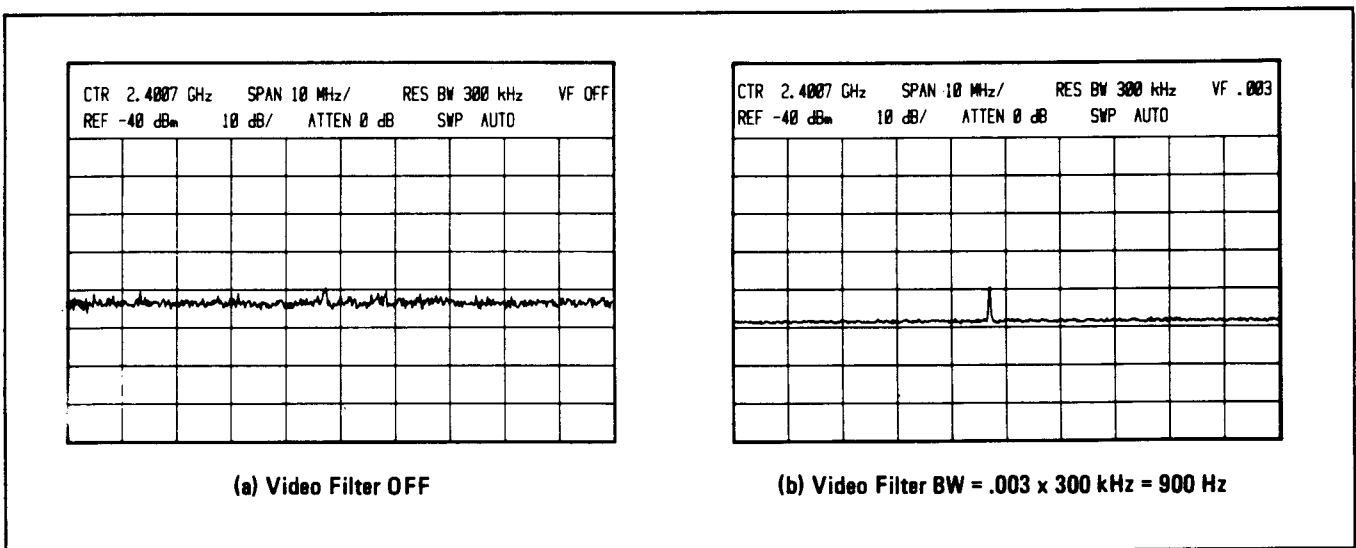

Figure 17. Video Filtering

## Sweep Time



When SWEEP TIME/DIV is set to AUTO, the sweep time is automatically adjusted for all FREQUENCY SPAN/DIV, RESOLUTION BW, and VIDEO FILTER settings to maintain a calibrated amplitude display. The effect of the AUTO SWEEP TIME/DIV setting may be observed by decreasing the VIDEO FILTER bandwidth setting. The sweep rate slows automatically to allow the narrow video filter bandwidths more time to respond. Calibrated sweep times from 2  $\mu$ sec/Div to 10 sec/Div are available when the SWEEP TIME/DIV control is not in AUTO. The faster sweep times (2  $\mu$ sec/Div to 1 msec/Div) are used only to display fast signal variations in the time domain (ZERO SPAN selected). At sweep speeds of 2 msec/Div and faster, a mixed mode is enabled in which the display characters and the illumination for the graticule remain digitally controlled while the displayed trace information is analog. At a sweep speed of 5 msec/Div, a mixed mode is enabled if the  DGT L AVG,  INP-B -A, or  MAX HOLD push button is pressed. When the mixed mode is enabled, the trace information cannot be transferred digitally.

When the SWEEP TIME/DIV control is operated manually (not in AUTO) or in any full-band mode, care must be taken to ensure that amplitude calibration is maintained. An uncalibrated display can easily be verified by the presence of the UNCAL readout in the CRT annotation. The SWEEP TIME/DIV control (AUTO or manual operation) will operate with any SWEEP TRIGGER setting as long as INT SWEEP SOURCE is selected.

### HP-IB Code:

ST (output SWEEP TIME/DIV or AUTO flag)  
TS (take sweep)  
SF (start sweep and set sweep flag)  
MS (output value of sweep flag)

## DIGITAL STORAGE DISPLAY

The spectrum analyzer CRT displays the signal response trace and all pertinent measurement data. The display information, provided at a flicker-free rate, can be stored for later reference. Certain arithmetic and signal processing functions such as MAX HOLD and digital averaging can be performed on the trace values.

The analyzer can output character information (Figure 18), or messages can be sent to the display via HP-IB.

### HP-IB Code:

LU,LL (input lower, upper line messages)  
AU,AL (display lower, upper line control settings)  
CS (output annotation)

## TRACES

Two independent traces (A and B) may be stored and then displayed either separately or simultaneously.

### Error Detection

UNCAL: Uncalibrated display. Gives indication of incompatible FREQUENCY SPAN, RESOLUTION BW, VIDEO FILTER or SWEEP TIME/DIV settings when SWEEP TIME/DIV is not set to AUTO.

\*: Invalid trace asterisk indicates that the displayed trace data has not been updated to reflect changes in control settings.

Display Error Messages: Provide feedback of incorrect control settings for the current measurement. (Display Error Messages are discussed later in this chapter.)

### Clear/Reset

CLEAR/RESET clears trace data from the CRT and resets sweep when the instrument is in a write mode. In  MAX HOLD and  DGT L AVG modes, the processed trace is cleared and the sequence restarted. If a plot is in progress, it is aborted. During HP-IB operation, CLEAR/RESET halts HP-IB communication and returns the display to front-panel control.

### Trace Modes

Four mutually exclusive modes for Trace A and Trace B determine the manner in which the traces of the input signal are displayed.

**Write Modes.** There are two write modes, in which the trace is updated, for Trace A and Trace B:

- WRITE displays the input signal response.
- MAX HOLD displays and holds the maximum responses of the input signal.

**Store Modes.** There are two store modes, in which the trace remains unchanged, for Trace A and Trace B:

- STORE VIEW stores the current trace and displays it on the CRT.
- STORE BLANK stores the current trace and blanks it from the CRT display.

When both Trace A and Trace B are in STORE BLANK, a single analog trace is displayed.

### HP-IB Code:

TA,TB (output Trace A, Trace B integer values)  
BA,BB (output Trace A, Trace B byte values)  
AP,BP (output Trace A, Trace B peak signal coordinates)  
IA,IB (input Trace A, Trace B integer values)

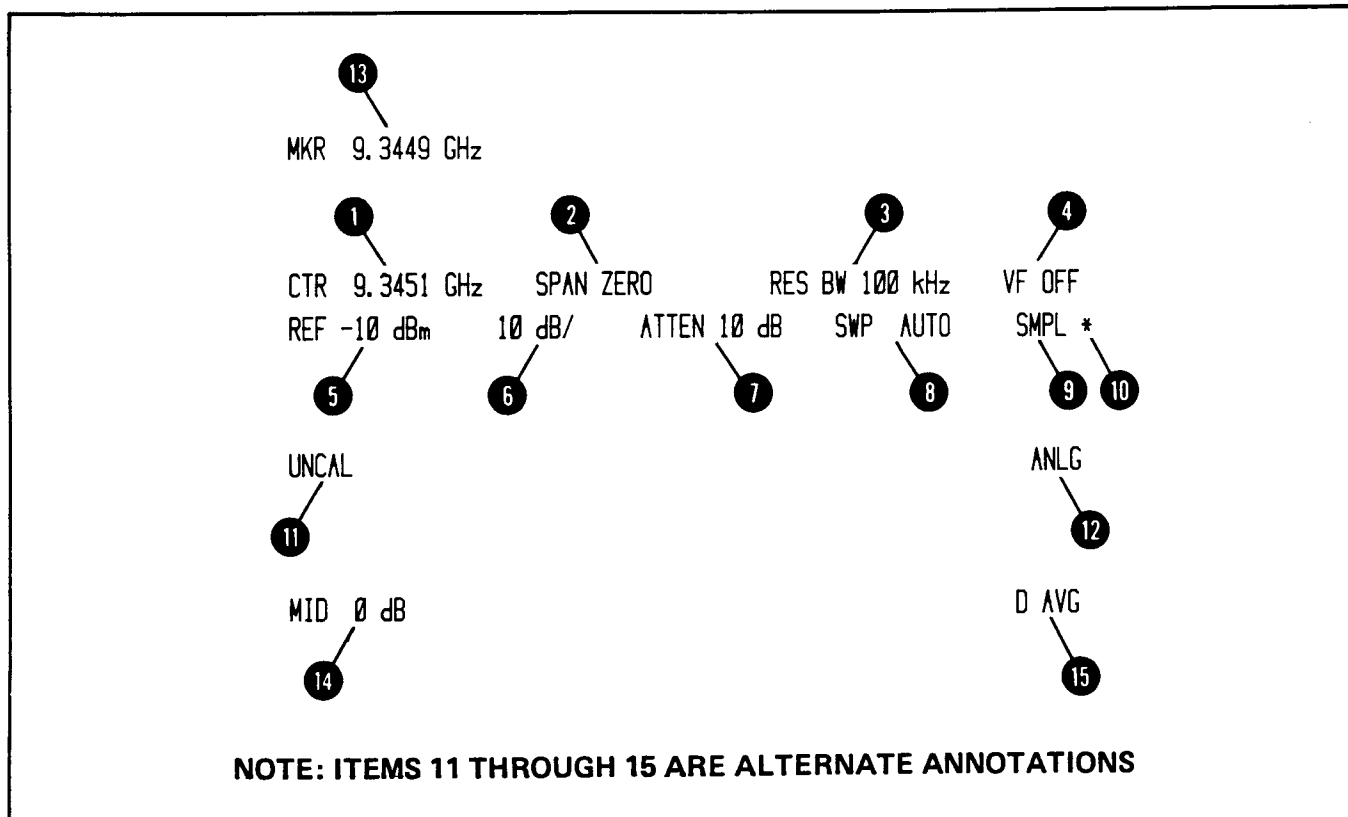

Item	Description	Item	Description
1	Center Frequency	9	Sample mode indication
2	FREQUENCY SPAN/DIV setting	10	Trace invalid indication
3	RESOLUTION Bandwidth setting	11	Uncalibrated display indication
4	Video Filter setting	12	ANALOG DISPLAY mode indication
5	Reference Level setting	13	Marker Frequency in Full and 1.7–22 GHz Span modes
6	Amplitude Scale factor setting	14	Reference Level (dB) at center graticule line
7	Input Attenuator setting	15	Digital Averaging indication
8	Sweep Source - Sweep Time/DIV setting		

Figure 18. CRT Annotation

### TRACE MEMORY

An understanding of the trace modes requires a description of trace memory and trace data transfer within the analyzer.

Display traces are not written directly to the CRT using the IF section video output (Figure 19). Instead, the video response is converted to digital information and stored in a trace memory which can then be transferred to the CRT display. The way in which the information is displayed depends upon the trace mode selected.

#### NOTE

**It is important to understand the difference between “sweep” and “refresh.”**

**In “sweep,” the spectrum analyzer sweeps across a frequency span and stores measured amplitude data in a trace memory.**

**In “refresh,” display memory data is transferred to the CRT.**

The video response is transferred into the trace memory at the sweep rate of the analyzer (selected sweep time). The trace memory is written to the CRT display at a refresh rate of about 55 Hz. This is rapid enough to prevent flickering of the trace on the CRT. Thus, trace intensities remain constant as analyzer sweep times are changed.

For write modes, the analyzer signal response is written into trace memory during the sweep, and the memory

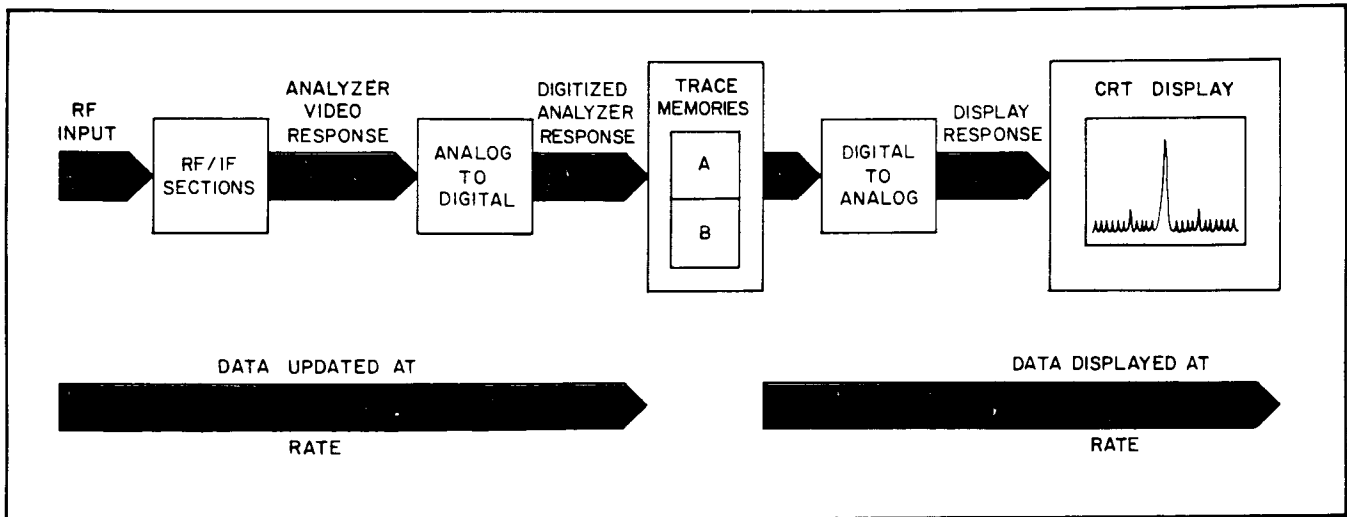

Figure 19. Data Acquisition and Transfer

contents are displayed on the CRT. In store modes, the trace memory is not updated. The current memory data is saved and is either displayed  STORE VIEW or blanked  STORE BLANK.

**Signal Processing**

One of two detection techniques can be selected for displaying trace information: Normal or Sample (Table 3).

Table 3. Detection Techniques

Mode	Access	Use
Normal	Default Mode Always selected if not in sample mode or in analog display	Most measurements when peak amplitude of response is desired
Sample	<input type="checkbox"/> SAMPLE pushed in	Random Noise Level measurements Digital Averaging (automatically selected) Zero Frequency Spans for sweeptimes $\geq 2$ msec/DIV for most time domain analysis

During a sweep, only a specified amount of time is available for writing data into each of the 481 trace memory addresses. In each one of these time periods, the positive peak detector obtains the maximum video signal excursions and stores this value into the trace memory address. In the sample mode ( SAMPLE), the instantaneous signal

value of the final analog-to-digital conversion for the time period is placed in memory (Figure 20).

In Figures 21 and 22, the same signal response is displayed with each trace detection mode.

**HP-IB Code:**

DM (output SAMPLE state)

**Digital Averaging**

DGTL AVG is a trace display routine that averages trace responses from sweep to sweep, thus averaging random noise without requiring a narrow video bandwidth. Maximum averaging is achieved after 64 sweeps. Both digital averaging and reduced video bandwidth are primarily used to improve the ability of the analyzer to measure low level signals by smoothing the noise response.

The advantage of digital averaging over narrowing the video filter is the ability for the user to view changes made to the amplitude or frequency scaling of the display while smoothing the noise response. For example, to display very low level signal responses, very narrow resolution and video bandwidths are required. The accompanying increase in sweep time can make measurements cumbersome. Digital averaging allows the display of low level signals without long sweep times. (Any change to control settings will cause the digital averaging process to be restarted.)

Display Error Message  MAX HOLD If either Trace A or Trace B is in the mode, an error message is displayed on the upper portion of the CRT.

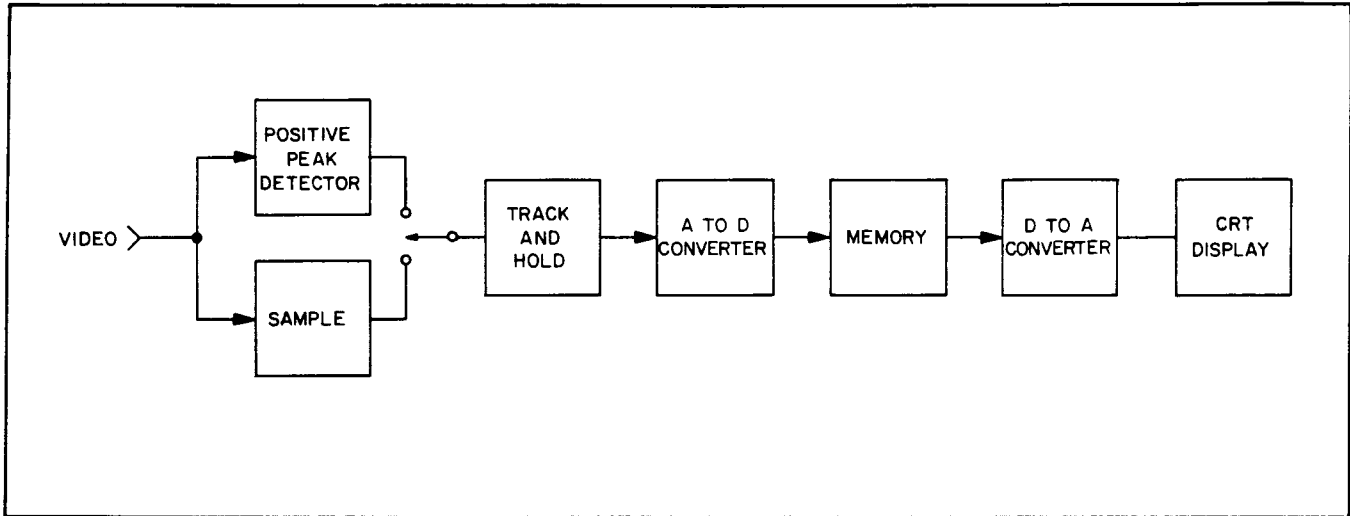

Figure 20. Detection Signal Flow

### Digital Averaging Algorithm

The average of each amplitude point depends on the number of samples already taken and the last amplitude average. The exponentially weighted algorithm is expressed

$$Y_N = Y_{N-1} + \frac{S_N - Y_{N-1}}{F}$$

- where  $Y_N$  = the latest measurement average
- $Y_{N-1}$  = the previous measurement average
- $S_N$  = the current measurement
- $N$  = sweep number
- $F = 2^{\text{INT}(1 + \text{LOG}_2(N))}$

In other words, the difference between the previous average and the current measurement is divided by F. The result is then added to the previous average to obtain the new average.

For each sweep when  $n > 64$ , F (now 64) remains constant, and all new data is weighted by  $1/64$  and added to the average amplitude after the most recent measurement. Therefore, the average follows only a slowly changing signal response.

### HP-IB Code:

DG (output DGTL AVG state)

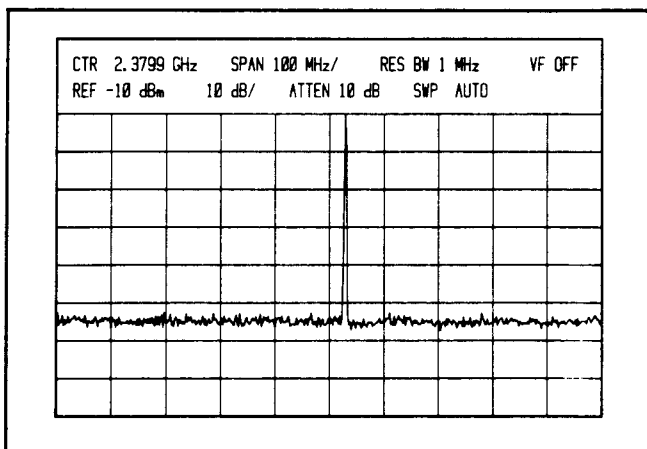

Figure 21. Normal Detection Mode

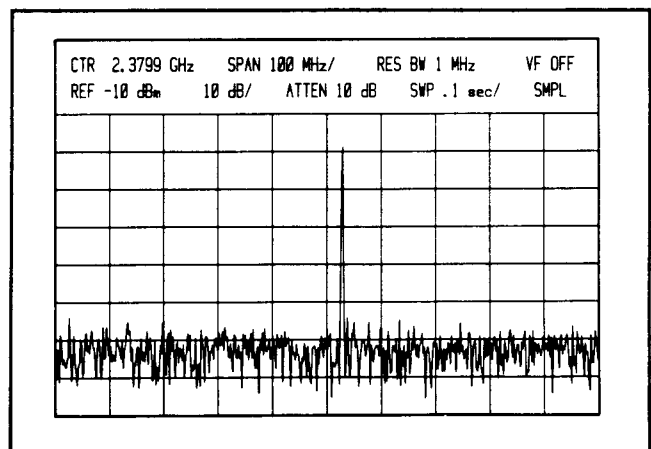

Figure 22. Sample Detection Mode



## Trace Arithmetic

Trace arithmetic can be used either for comparison of two traces or for normalization in swept frequency measurements.



Trace B amplitude (measured in divisions from the bottom graticule) is subtracted from the input trace (Trace A), and the result is written into Trace A from sweep to sweep. Trace B must be in one of the STORE modes.

Display Error Message

If Trace B is not in  STORE VIEW or  STORE BLANK, an error message is displayed in the upper portion of the CRT.

Trace arithmetic can be used to correct for the frequency response characteristics (flatness) of a swept measurement system. (Refer to Chapter 3 for more detail.)

## HP-IB Code:

NS (output INP – B → A state)

## DIRECT PLOTTER OUTPUT

Graticule  GRAT, character  CHAR, and trace  TRACE information can be output directly to a digital plotter through an HP-IB cable, without the need for a controller.

## NOTE

**If an HP-IB controller is connected to the HP-IB output of the HP 8569B, place controller in reset state (terminate any running program) before the direct plot routine is executed.**

Digital plotters can provide full-size copies – up to 11 by 16 inches (approximately 279 by 406 mm) with the HP 9872B – that are ideal for lab reports and that can be reproduced more easily than photographs.

The HP 7225A and HP 9872B are among the plotters that are directly compatible with the HP 8569B. (Most of the CRT illustrations in this manual were directly plotted with the HP 7225A.)

To generate a plot:

1. Attach HP-IB cable from the HP-IB connector on the rear panel of the HP 8569B to the plotter rear panel HP-IB connector as shown in Figure 25.
2. Establish the lower-left and upper-right limits on the plotter.
3. Press and release  GRAT to plot graticule,  CHAR to plot characters, and  TRACE to plot trace data. (The plots may be run individually, or all three push buttons may be pressed immediately to run a complete plot of the total CRT display.)

To stop the direct plot routine, depress  CLEAR/RESET.

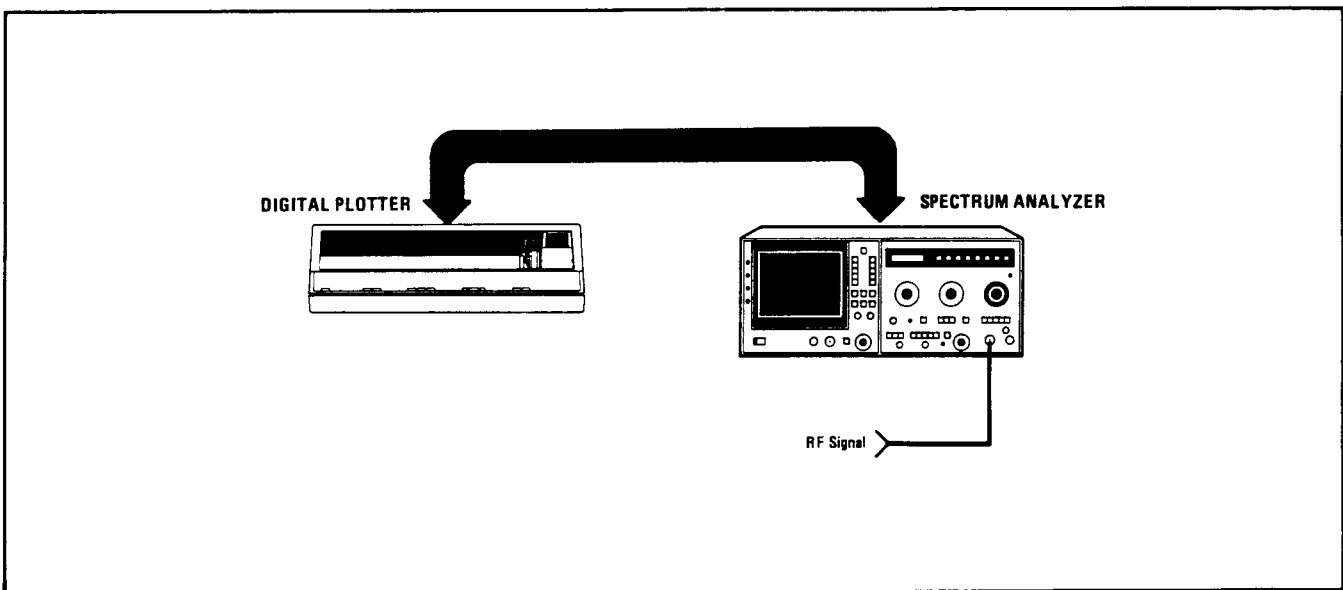

Figure 23. Digital Plotter Setup

## CHAPTER 3 SPECIAL TOPICS

### MAXIMUM DYNAMIC RANGE

Dynamic range is defined as the ratio of the largest to the smallest signal that can be measured without any interference from analyzer distortion products or internal noise. The maximum dynamic range occurs when the internally generated distortion of the analyzer is equal to its noise level (thus, the dynamic range is limited equally by both).

Mixer distortion, caused by a large signal at the mixer, changes non-linearly as the fundamental signal amplitude is changed. That is, for example, a 10 dB change in amplitude causes a 20 dB change in second-order distortion level and a 30 dB change in third-order distortion. Therefore, the objective of the following discussion is to show that maximum dynamic range can be achieved by the judicious use of RF attenuation.

The maximum dynamic range of the HP 8569B can be determined by referring to Figure 26. Three types of curves are presented on the chart: sensitivity (solid line), second-order distortion (large dashed line), and third-order distortion (small dashed line). The sensitivity curves for the six internal frequency bands (0.01 – 22 GHz) are given for a 100 Hz bandwidth. To use the sensitivity curves for other resolution bandwidths, simply subtract 10 dB from the signal to noise reading for an increase in resolution bandwidth by a factor of 10. For example, a signal to noise ratio of 70 dB for a 100 Hz bandwidth would be 60 dB for a 1 kHz bandwidth. The second- and third-order distortion curves are dependent on whether the 0.01 to 1.8 GHz band or one of the preselected internal mixing bands is used. When more than one signal is at the RF input to the mixer, the distortion curves are also dependent on signal separation. Two vertical axes are used in Figure 26: Signal to Noise Ratio (right side) and Spurious-Free Dynamic Range (left side). The maximum dynamic range occurs at the intersection of the particular sensitivity curve and distortion curve under consideration. This point is obtained on the spectrum analyzer by adjusting the RF input attenuation to achieve the appropriate signal amplitude at the mixer.

Two major factors determine the maximum achievable dynamic range of the HP 8569B. They are:

1. Signal level at the Input Mixer.

2. Sensitivity of the analyzer (dependent on frequency band and resolution bandwidth).

These two factors are examined separately in the following paragraphs.

### Mixer Level

The Mixer Level is simply the signal at the input minus the analyzer INPUT ATTEN setting. In equation form:

$$\text{Mixer Level} = \text{Input Signal} - \text{INPUT ATTEN}$$

The horizontal axis on the dynamic range chart represents the Mixer Level.

Dynamic range varies as a function of Mixer Level. In the 0.01 to 1.8 GHz range, the Mixer Level (for maximum dynamic range) should be approximately – 47 dBm when second-order distortion products are measured. Beyond this level, second-order distortion will increase 20 dB for every 10 dB increase in Input Signal. For third-order distortion measurements, the Mixer Level should be approximately – 37 dBm. In the preselected 1.7 to 22 GHz frequency range, dynamic range variation as a function of Mixer Level is not as critical. The maximum dynamic range in the preselected bands is achieved at a Mixer Level of approximately – 7 dBm, which is the 1 dB gain compression level of the spectrum analyzer. This applies for both second- and third-order distortion products.

Example (see Figure 26).

Measure the third-order intermodulation distortion products of a device. The spectrum analyzer input signals are 1146 MHz and 1156 MHz and have an amplitude of – 10 dBm. Find the Mixer Level to obtain the maximum dynamic range, insuring that the distortion of the spectrum analyzer does not interfere with measuring the distortion products of the device.

Solution:

The Mixer Level to achieve the maximum dynamic range is approximately – 37 dBm (about – 40 dBm for each signal). Since this is a third-order measurement, use the small dashed third-order distortion curve applicable to the frequency range. Intersect this curve with the sensitiv-

ity curve that cover 0.01 to 1.8 GHz. The maximum dynamic range and optimum Mixer Level for a 100 Hz resolution bandwidth occurs at the intersection of the curves. The INPUT ATTEN control must therefore be set at 30dB (for a total power level at the mixer of -37 dBm) to achieve this dynamic range (see Figure 26a).

### Sensitivity

Spectrum analyzer sensitivity has been traditionally defined as the average noise level displayed on the analyzer. The average noise level of the HP 8569B is dependent on the resolution bandwidth and on the frequency band selected. Since the noise displayed on the analyzer is random, it is dependent on bandwidth; therefore, for every decade increase (decrease) in resolution bandwidth the average noise level increases (decreases) by 10 dB.

The HP 8569B uses harmonic mixing to achieve 22 GHz (internal mixing) and 115 GHz (external mixing) frequency ranges. Thus, higher harmonic mixing modes (corresponding to higher frequency bands) have higher average noise levels, causing spectrum analyzer sensitivity to decrease). Therefore, the best sensitivities are achieved on the lower frequency bands. Figure 26c shows how the Signal to Noise Ratio is degraded with the higher frequency bands.

### Preselection

Another factor to consider in determining maximum dynamic range, besides mixer level and sensitivity, is preselection. In comparing the distortion curves for the 1.7

to 22 GHz frequency range to the 0.01 to 1.8 GHz frequency range in Figure 26c, it can be seen that the dynamic range for the preselected band (1.7 to 22 GHz) is generally much greater when the signal separation is  $\geq 100$  MHz. This benefit is due to the tracking preselector, a tunable bandpass filter that tracks the tuning of the analyzer. The preselector extends the dynamic range of the analyzer to measure a low level signal in the presence of a potentially interfering high level signal. Since the preselector tracks the tuning of the analyzer, it allows a signal to pass to the mixer when both preselector and analyzer are tuned to receive it. When the analyzer is tuned to the low-level harmonic, the preselector rejects the high-level fundamental, thus preventing internal distortion products from affecting the measurement. This condition is illustrated in Figure 24.

In the preselected frequency bands (1.7 to 22 GHz) the tracking bandpass filter has a nominal 50 MHz bandwidth and a worst case rejection of  $>60$  dB (60 dB - 18 to 22 GHz, 70 dB - 1.7 to 18 GHz). For signal separation  $\geq 100$  MHz, the tracking filter will allow only one signal to pass to the mixer while simultaneously rejecting the other signal. This is illustrated in Figure 25. Since only one signal is seen at the mixer at any instant of time, the third-order distortion products of the analyzer are significantly reduced. Also, for larger signal separation, the preselector has more rejection and hence the dynamic range is greater.

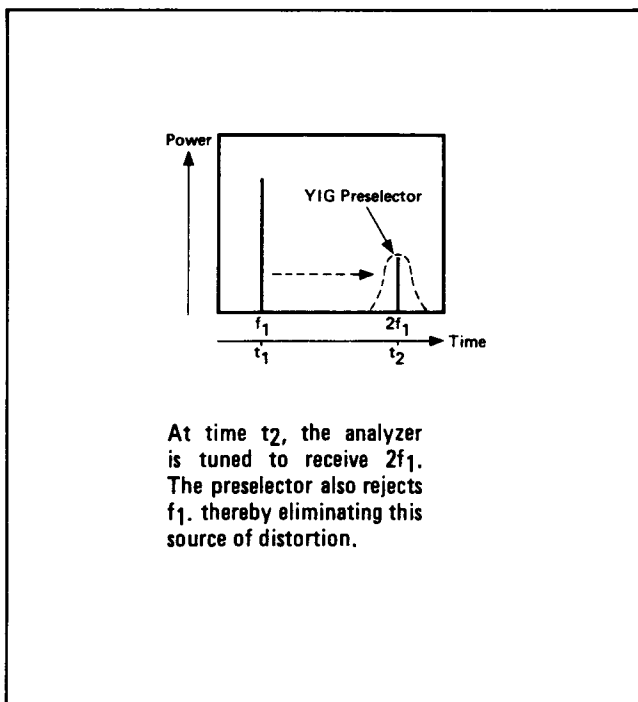

Figure 24. YIG Preselector Tuning

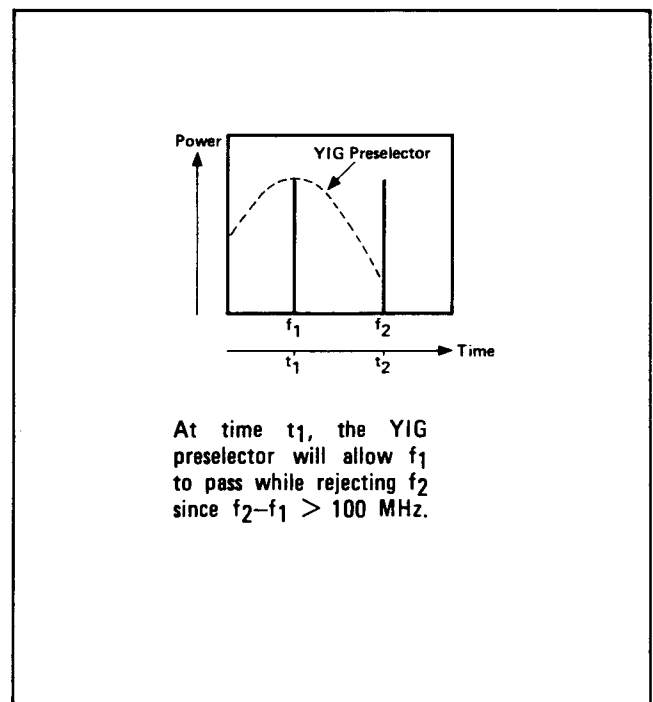
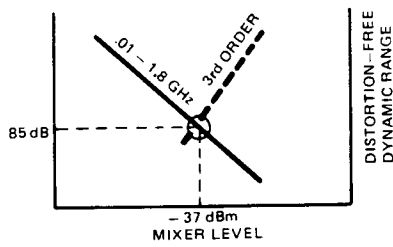
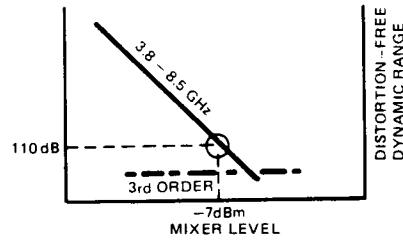

Figure 25. YIG Preselector Passband



(a)



(b)

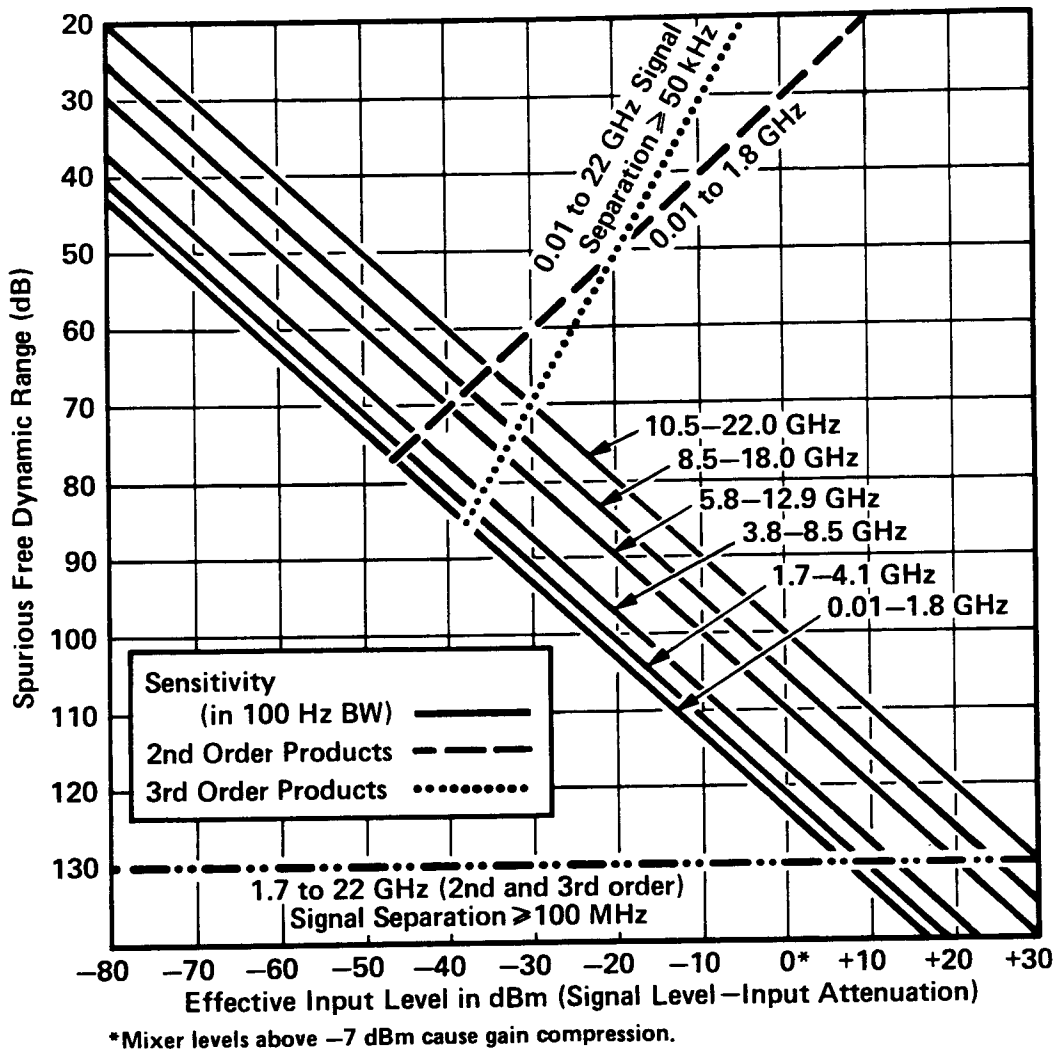

(c)

Figure 26. Dynamic Range

The distortion curves for the 1.7–22 GHz frequency range are represented by a horizontal line. The line represents both the second- and third-order distortion curves, which theoretically have the same slope as the distortion curves in the non-preselected modes. However, the curves are represented as a horizontal line because the absolute levels of the internally generated distortion are generally well below the internally generated noise of the analyzer.

Example:

Measure the third-order intermodulation products of a microwave amplifier. The two output signals are –10 dBm at 5.9 and 6.1 GHz. What is the maximum dynamic range of the analyzer?

Solution:

The maximum dynamic range is approximately 110 dB. Note that the signal separation is 200 MHz; therefore, the second- and third-order distortion of the analyzer is represented by the distortion curve for the preselected band (1.7 to 22 GHz with signal separation  $\geq 100$  MHz). For a mixer input level of –7 dBm (–10 dBm for each signal) the distortion curve is below the sensitivity curve of the analyzer; therefore, the dynamic range is determined by the intersection of the 3.8–8.5 GHz sensitivity curve with the –7 dBm mixer level. The dynamic range of the analyzer is approximately 110 dB (see Figure 26b).

**Other constraints:** When measuring distortion products associated with low-level input signals, the noise floor of the analyzer is the limitation. In this case, find the input signal level on the Mixer Level (horizontal) axis (assuming INPUT ATTEN is set to 0 dB) and go vertically to the appropriate sensitivity curve. The maximum obtainable dynamic range is read from the Signal to Noise ratio (vertical) axis.

### Dynamic Range Equations

The dynamic range chart shown in Figure 26 is based on the following equations for third- and second-order maximum dynamic range.

For third-order =  $\left| \frac{2}{3} (\text{average noise level} - \text{TOI}) \right|$  in dB

For second-order =  $\left| \frac{1}{2} (\text{average noise level} - \text{SOI}) \right|$  in dB

The third-order intercept (TOI) is theoretically defined as the mixer level at which third-order distortion equals the fundamental signal level (a condition which never occurs because compression in the mixer occurs first). The second-order intercept (SOI) is theoretically defined as the mixer level at which second-order distortion equals the fundamental signal level. The intercept is calculated from the following equation:

$$\text{Intercept} = \text{mixer level} - (\text{distortion (dBC)})/N - 1$$

where N = order of distortion

These equations are used to compute the best dynamic range for either third- or second-order distortion products and noise. The noise level is the displayed noise level for the resolution bandwidth and center frequency to be used, assuming 0 dB input attenuation.

Example: In measuring a 10.50 GHz signal and a 10.55 GHz signal in a 1 kHz resolution bandwidth, the typical sensitivity of the analyzer is –100 dBm, assuming 0 dB input attenuation. The HP 8569B has a TOI of +5 dBm and SOI of +30 dBm for signal separations of <100 MHz. What is the maximum dynamic range?

Solution:

70 dB for third-order and 65 dB for second-order.

$$\begin{aligned} \text{Third-order} &= \left| \frac{2}{3} (-100 \text{ dBm} - +5 \text{ dBm}) \right| \\ &= 70 \text{ dB} \end{aligned}$$

$$\begin{aligned} \text{Second-order} &= \left| \frac{1}{2} (-100 \text{ dBm} - +30 \text{ dBm}) \right| \\ &= 65 \text{ dB} \end{aligned}$$

It is also possible to determine the value of total RF attenuation (internal or external) needed to obtain the maximum dynamic range for a given input power level from the following equations.

For third-order:

$$\text{Atten} = \text{Input} - \frac{2}{3} \text{TOI} - \frac{1}{3} \text{Noise Level}$$

For second-order:

$$\text{Atten} = \text{Input} - \frac{1}{2} \text{SOI} - \frac{1}{2} \text{Noise Level}$$

For the same conditions as in the previous example, with total Input Signal Level of –20 dBm, the RF attenuation should be set to:

Third-order:

$$\begin{aligned} \text{Atten} &= -20 \text{ dBm} - \frac{2}{3}(+5 \text{ dBm}) - \frac{1}{3}(-100 \text{ dBm}) \\ &= 10 \text{ dB} \end{aligned}$$

Second-order:

$$\begin{aligned}\text{Atten} &= -20 \text{ dBm} - 1/2(+30 \text{ dBm}) - 1/2(-100 \text{ dBm}) \\ &= 15 \text{ dB}\end{aligned}$$

Therefore, RF attenuation must be set to 10 dB to maximize third-order and 15 dB to maximize second-order dynamic range.

## IMPROVING AMPLITUDE MEASUREMENT ACCURACY

The technique known as IF substitution can be used to improve measurement accuracy on the HP 8569B. The IF substitution method uses only the accurate IF gain of the analyzer to position the signal on the calibrated REFERENCE LEVEL line. In this way, errors caused by CRT non-linearity, log amplifier, input attenuator, and bandwidth filter will be eliminated. The IF gain of the analyzer is controlled with the calibrated REFERENCE LEVEL dBm control.

### Amplitude Measurement with IF Substitution

The steps for achieving accurate amplitude measurements with IF substitution are as follows:

1. Set the INPUT ATTEN control to 10 dB or greater. This ensures a good input SWR to minimize mismatch errors.
2. Set the FREQUENCY SPAN/DIV and RESOLUTION BW controls to the desired settings.
3. Connect the CAL OUTPUT signal to the analyzer to verify calibration.
4. Disconnect the CAL OUTPUT signal and connect the signal to be measured.
5. Press the desired FREQUENCY BAND push button and use only the TUNING control to center the signal on the CRT.
6. In the 1.7 to 22 GHz frequency range, adjust the PRESELECTOR PEAK control to maximize the signal level.<sup>4</sup>

<sup>4</sup>The best broadband tracking performance of the preselector is normally obtained with the PRESELECTOR PEAK control centered in the green area. However, for accurate power measurement, the PRESELECTOR PEAK control should be adjusted to maximize signal level every time an amplitude measurement is made.

7. Now, using only the REFERENCE LEVEL dBm control and vernier, position the peak of the signal on the REFERENCE LEVEL line of the CRT. The signal amplitude is indicated by the REF on the CRT annotation.

When the IF substitution technique is used for amplitude measurements, the only remaining measurement uncertainties are due to the CAL OUTPUT signal, flatness, and REFERENCE LEVEL control accuracy of the analyzer. Uncertainties caused by log amplifier fidelity, CRT non-linearities, and RESOLUTION BW and INPUT ATTEN switching errors have been eliminated because they were left unchanged throughout the measurement.

Further improvement in accuracy can be achieved by calibrating the analyzer at the same frequency to which the measurement will be made. This would eliminate any flatness uncertainties, and the measurement accuracy would be dependent only upon the accuracy of the calibration signal and the REFERENCE LEVEL control.

## CRT PHOTOGRAPHY AND X-Y RECORDING

### CRT Photography

The CRT annotation on the HP 8569B display provides an excellent means of information retention with the use of any compatible scope camera. Since the display has readouts for all major spectrum analyzer settings, the need for additional writing on the photograph is largely eliminated. Also, interference between trace and characters is not a problem because the character annotation is located on the upper portion of the display, outside the graticule (refer to Figure 27).

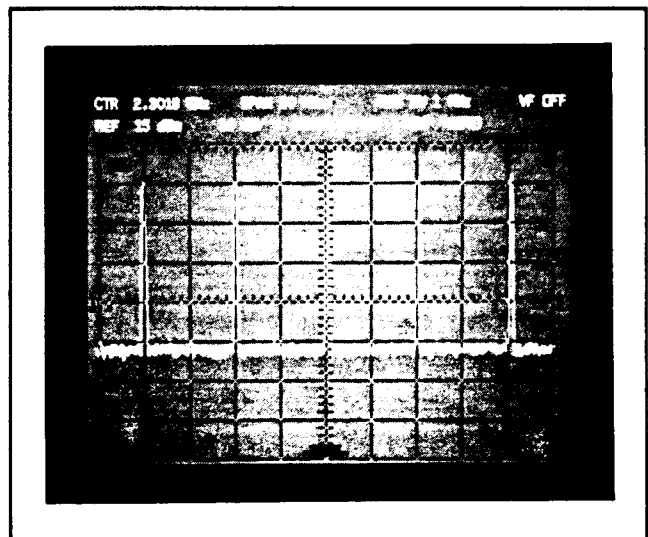

Figure 27. CRT Display with Character Annotation

The photo in Figure 27 was taken with a camera that has variable shutter speed and f-stop. A step-by-step procedure for photography is given below. These steps are applicable with the HP 197B Option 006 or other compatible scope cameras.

### Photography Procedure

1. Set the HP 8569B SCALE INTEN and INTEN to the calibrated blue markings.
2. Set the camera shutter to 2 seconds and the f-stop to 8.
3. Push the  STORE VIEW button on the analyzer to store the trace. This ensures the trace and the CRT frequency readout on the display will not change while the camera shutter is opened. Press shutter on camera to take picture.

In the mixed display mode (refer to Appendix B), a double exposure is needed to provide the best contrast between signal trace, graticule lines, and CRT annotation.

### Double Exposure Photography

1. Set INTEN fully counter-clockwise.
2. Set SCALE INTEN to calibrated blue markings.
3. Set SWEEP TIME/DIV to AUTO.
4. Set shutter speed to  $\geq 2$  sec and f-stop to 8.
5. Press shutter on camera to take first exposure.
6. Return SWEEP TIME/DIV to original setting.
7. Set INTEN to the calibrated blue markings.
8. Press  STORE VIEW .
9. Press shutter on camera to take second exposure.

To set up the initial focusing of the camera the user is referred to the Operation Section of the 197B Operation and Service Manual (HP Part Number 00197-90915).

### Analog X-Y Recording

The HP 8569B is directly compatible with the HP line of X-Y recorders as well as strip-chart and magnetic tape recorders. The VERTICAL OUTPUT, BLANK OUTPUT, and HORIZONTAL SWEEP OUTPUT are available from the rear panel of the analyzer. As with digital

plotters, X-Y recorders can provide full-size, high-resolution copies – up to 11 by 14 inches (approximately 279 to 356 mm) – that are more convenient than photographs for laboratory report folders. Figure 28 illustrates a typical setup used for X-Y recording.

The bandwidth of most X-Y recorders is very narrow, typically 1 to 2 Hz. This narrow bandwidth requires a sweep rate that is slow enough for the recorder to fully respond to a signal. In general, a sweep rate of 2 sec div is sufficient for most X-Y recorders. The SINGLE or the MANUAL sweep mode on the HP 8569B can be used to control the sweep.

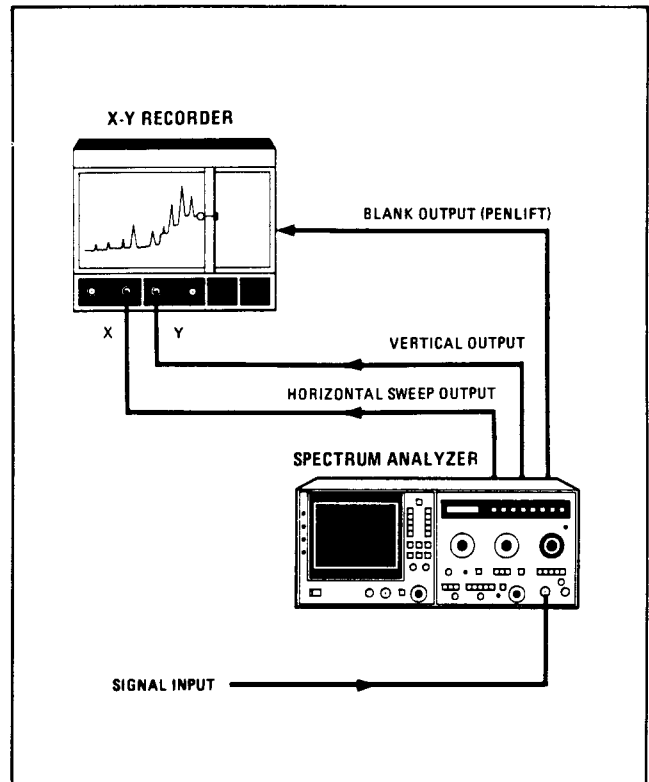

Figure 28. X-Y Recorder

### EXTERNAL MIXER OPERATION

Calibrated frequency coverage from 12.4 to 40 GHz can be achieved by using the HP 11517A Option E03 External Mixer. Coverage above 40 GHz can be accomplished with a variety of commercially available mixers. The HP 11517A must be used with the appropriate waveguide adapter listed in Table 4. The external mixer connects to the IF INPUT port on the front panel of the HP 8569B by means of a coaxial cable that has male SMA connectors. Selection of the EXT MIXING MODE and the corresponding FREQUENCY BAND allows frequency coverage in four ranges: 12.4 to 26.5 GHz, 21 to 44 GHz, 33 to 71 GHz, and 53 to 115 GHz.

Table 4. External Mixer Components

HP Model Number	Description	HP Band Designation
11517A	12.4–40 GHz Mixer	
11518A	12.4–18 GHz Adapter	P
11519A	18–26.5 GHz Adapter	K
11520A	26.5–40 GHz Adapter	R

External mixers are used whenever the signal of interest is higher in frequency than the design limits of the coaxial input and internal mixer of the spectrum analyzer. Consider these four signals when using external mixers: the RF input, the spectrum analyzer first LO, the bias current for the mixer diode, and the IF output of the mixer. Some mixers have separate ports for each signal. One port is for the RF input. The other port is shared by the LO power and DC bias current inputs, and IF output. The HP 11517A is a two-port device. A diplexer (HP Part Number 5086-7721) must be used to separate the DC current from the LO power. A test setup of the HP 8569B with the HP 11517A External Mixer and adapter, and the diplexer, is illustrated in Figure 29.

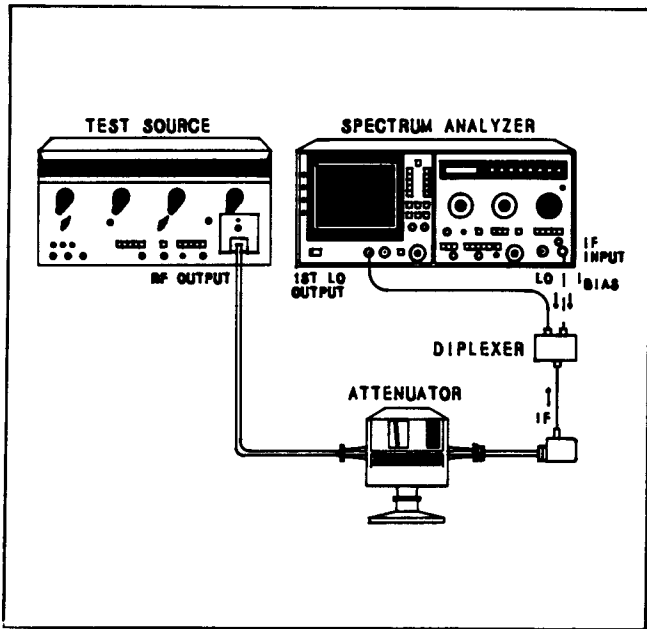

Figure 29. External Mixer Test Setup

A DC bias is necessary to optimize single diode mixers for minimum conversion loss at the frequency of the RF input signal. The HP 8569B can supply negative or positive DC bias. For positive polarity mixers such as the HP 11517A, the bias can vary from 0 to +5 mA. For negative polarity mixers, the bias can vary from -5 to 0 mA.

In operation, the HP 11517A External Mixer bypasses the input attenuator, preselector, and the internal mixer of the analyzer. Three things must be remembered when using the external mixer:

1. The INPUT ATTEN has no effect on the input signals.
2. Harmonic mixing responses must be properly identified, since there is no preselection in the EXT MIXER bands. With a FREQUENCY SPAN/DIV of 100 MHz, the HP 8569B displays mixing product pairs. The correct pair is 642.8 MHz apart. The lower frequency product of the pair is the correct one. To check this, center this signal on the display. Select FREQUENCY SPAN/DIV of 1 MHz and press the SIG IDENT button. The display should show two signals with 2 MHz separation.
3. Amplitude measurements are uncalibrated unless steps are taken to calibrate the analyzer. Refer to Section V, paragraph 5-31, in the HP 8569B Operation and Service Manual.

### Signal Identification

To properly identify a signal on the CRT, the SIG IDENT push button on the HP 8569B is used. To use the SIG IDENT, center the unknown response on the CRT. Then press the SIG IDENT push button and note whether the response resembles that shown in Figure 30. If the

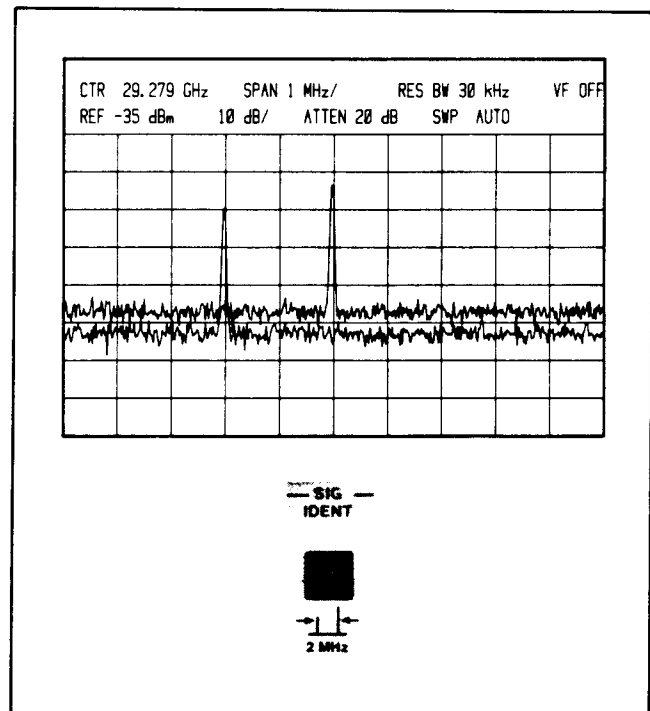

Figure 30. Signal Identifier



response moves to the left 2 MHz and drops in amplitude, it is the correct signal and its frequency is indicated on the display. When a signal cannot be identified in any of the EXT MIXER frequency bands, one of two conditions applies:

1. The signal is not in the 12.4 to 115 GHz frequency range.
2. The displayed response is a product generated by a harmonic of the Local Oscillator not utilized by the analyzer in displaying amplitude calibrated signals. However, there is a displayed response on one or more of the frequency bands which will identify the signal correctly.

In either case the signal frequency can be approximated from the following equation:

$$F_s = NF_{LO} \pm F_{IF} \quad (1)$$

where  $F_s$  = input signal

$N$  = mixing mode

$F_{LO}$  = first local oscillator frequency

$F_{IF}$  = first intermediate frequency

The first step in calculating the input frequency is to calculate the actual mixing mode ( $N_A$ ) using the following equation.

$$N_A = \frac{2 \text{ MHz}}{\text{Signal Shift (MHz)}} \times N \text{ of frequency band selected} \quad (2)$$

where  $N$  = harmonic mixing mode

$N_A$  = actual mixing mode

Signal Shift = signal shift on CRT in MHz with ON

The next step in the determination of  $F_s$ , the actual input signal, is to calculate the local oscillator fundamental frequency. Referring to equation (1), the LO fundamental frequency can be calculated from the value of  $F_s$  (obtained from CRT or LED center FREQUENCY GHz display),  $N$  (determined from the FREQUENCY BAND selected), and  $F_{IF}$  (first Intermediate frequency of the HP 8569B which equals 321.4 MHz). The “+” or “-” sign is determined by the polarity of the mixing mode of the frequency band selected.

For example,

$$\text{If } F_s = 34.5 \text{ GHz}$$

$$N = 10+$$

$$F_{IF} = 321.4 \text{ MHz}$$

From equation (1)

$$F_s = NF_{LO} \pm F_{IF}$$

$$34.5 \text{ GHz} = (10) \times F_{LO} + 321.4 \text{ MHz}$$

$$F_{LO} = 3.42 \text{ GHz}$$

The final step is to calculate  $F_s$  (the actual input signal) using equation (1), and the value of  $F_{LO}$ ,  $N_A$ , and  $F_{IF}$ . The “+” or “-” sign in this final calculation is determined by the direction of the signal shift. A shift to the left requires the “+” sign, while a shift to the right requires the “-” sign.

Example:

A signal displayed on the HP 8569B has a center FREQUENCY GHz readout of 38.00 GHz. When the  button is pressed, a second signal appears offset to the left by 4 MHz. What is the actual frequency of the signal?

Solution:

1. Calculate  $N_A$  using equation (2) while noting that 38.00 GHz is within the 21 – 44 GHz band, which has  $N = 10+$ .

$$N_A = (2 \text{ MHz}/4 \text{ MHz}) \times 10$$

$$N_A = 5$$

2. Calculate  $F_{LO}$  using equation (1) using

$$F_s = 38.00 \text{ GHz (center FREQUENCY GHz readout)}$$

$$N = 10 \text{ (corresponding to 21 – 44 GHz band)}$$

$$F_{IF} = 321.4 \text{ MHz (EXT MIXER 1st Intermediate frequency)}$$

Therefore,

$$38.0 \text{ GHz} = 10 \times f_{LO} + 321.4 \text{ MHz}$$

$$F_{LO} = 3.77 \text{ GHz}$$

#### NOTE

$F_{LO}$  can also be obtained from Tuning Curves on Figure B-2.

## CHAPTER 4 TYPICAL MEASUREMENTS

### DISTORTION

Distortion measurement is an area in which the spectrum analyzer makes a significant contribution. Two basic types of distortion are usually specified by the manufacturer: harmonic distortion and two-tone, third-order intermodulation distortion. The third-order intermodulation products are represented by:  $2f_1 - f_2$  and  $2f_2 - f_1$  where  $f_1$  and  $f_2$  are the two-tone input signals.

The HP 8569B is capable of making a wide variety of distortion measurements with speed and precision. The instrument can measure harmonic distortion products greater than 100 dB down in the 1.7 to 22 GHz frequency range. Third-order intermodulation products can also be measured greater than 100 dB down, depending on signal separation and frequency range.

### Amplifiers

All amplifiers generate some distortion at the output, and these distortion products can be significant if the amplifier is overdriven with a high-level input signal. The test setup in Figure 31 was used to measure the third-order intermodulation products of a microwave field-effect transistor (FET) amplifier. Directional couplers and attenuators were used to provide isolation between sources.

Figure 32 is a CRT plot of a two-tone, third-order intermodulation measurement. The third-order products ( $2f_1 - f_2$  and  $2f_2 - f_1$ ) are below the two-tone signals ( $f_1$  and  $f_2$ ).

### Mixers

Mixers use the non-linear characteristics of an active or passive device to achieve a desired frequency conversion. As a result some distortion at the output is due to the inherent non-linearity of the device. Figure 33 illustrates the test setup and CRT plot of a typical mixer measurement. Once the RF input and LO input signals were measured on the spectrum analyzer, from a single display, the following information was determined:

Conversion loss (SSB):

$$RF_{in} - IF = (-25) - (-34) = 9 \text{ dB}$$

LO to IF isolation:

$$LO_{in} - LO_{out(IF)} = (+5) - (-38) = 43 \text{ dB}$$

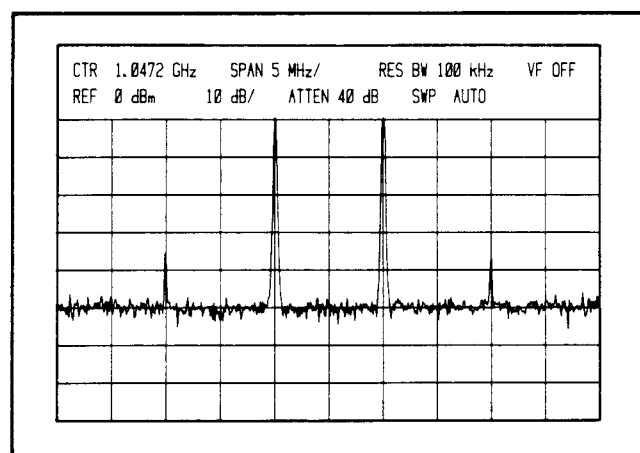

*Figure 32. Two-Tone, Third Order Intermodulation Products*

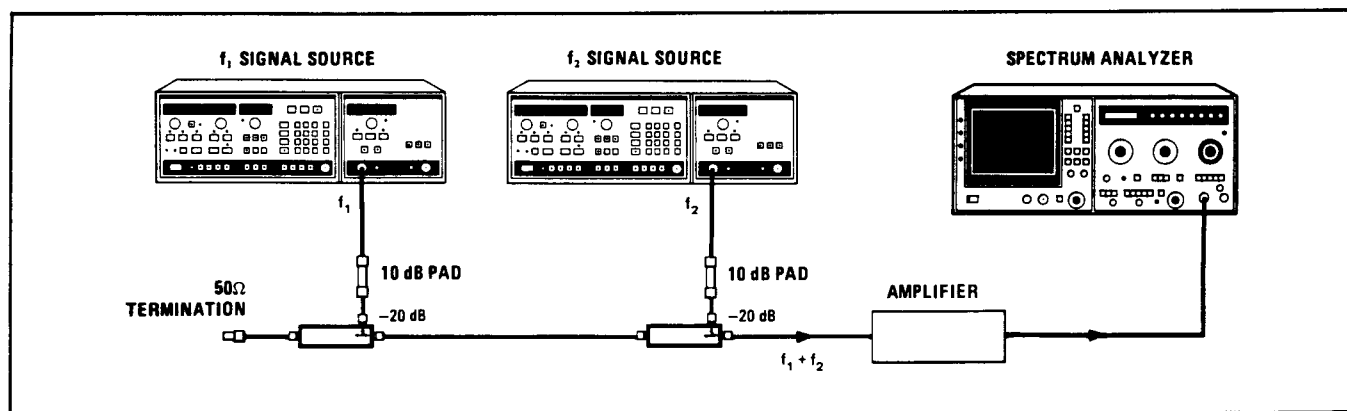

*Figure 31. Two-Tone Test Setup*

RF to IF isolation:

$$RF_{in} - RF_{out(IF)} = (-25) - (-54) = 29 \text{ dB}$$

Third-order distortion product (2 LO - RF):

- 74 dBm at 360 MHz.

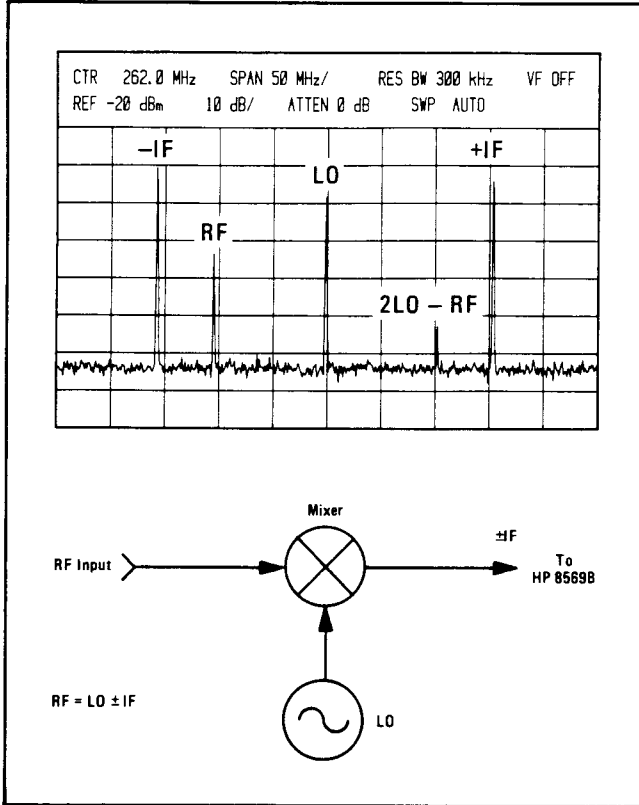

Figure 33. Mixer Measurement

## Oscillators

Distortion in oscillators may be harmonically or non-harmonically related to the fundamental frequency. Non-harmonic oscillator outputs are usually termed spurious. Both harmonic and spurious outputs of an oscillator can be minimized with proper biasing and filtering techniques. The HP 8569B can monitor changes in distortion levels while modifications to the oscillator are made. In the full-band modes, a tuning marker can be located under any signal response to determine its frequency and, hence, its relationship to the fundamental frequency of the oscillator. Figure 34 is a CRT plot of the fundamental and second harmonic of an S-band (2 to 4 GHz) YIG oscillator. The internal preselector of the HP 8569B enables the analyzer to measure a low-level harmonic in the presence of a high-level fundamental. The plot was obtained using the  MAX HOLD capability of the analyzer to allow storage of the maximum deviations of the signals.

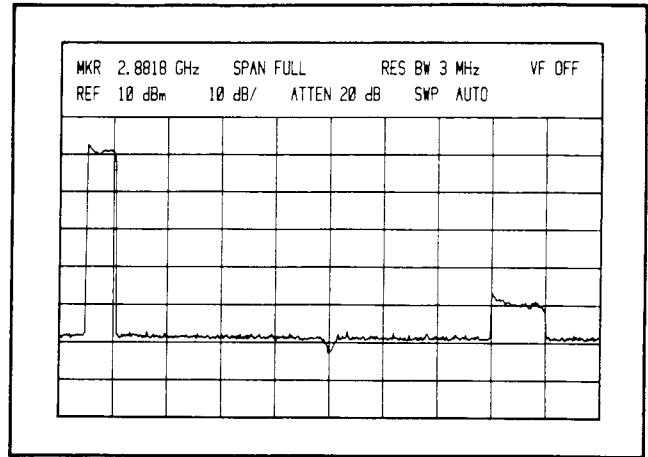

Figure 34. Oscillator Fundamental and Second Harmonic

## NOTE

Consult AN 150-11 for more information on distortion measurements.

## MODULATION

### Amplitude Modulation

The wide dynamic range of the spectrum analyzer allows accurate measurement of modulation levels. A 0.06 percent modulation is a logarithmic ratio of 70 dB, which is easily measured with the HP 8569B. Figure 35 shows a signal with 2 percent AM displayed, a log ratio of 40 dB.

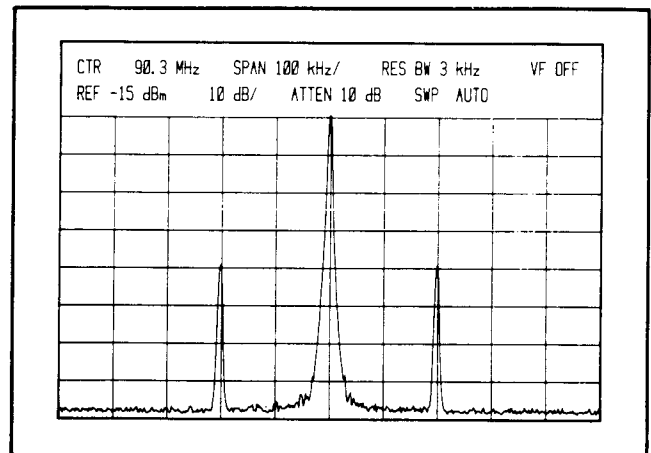

Figure 35. 2% AM

When the analyzer is used as a manually tuned receiver (Zero Span), the AM signal is demodulated and viewed in the time domain. To demodulate an AM signal, uncouple the RESOLUTION BW and set it to a value at least twice the modulation frequency. Then set the AMPLITUDE SCALE to LIN and center the signal,

horizontally and vertically, on the CRT. (Refer to Figure 38.) By pressing ZERO SPAN and VIDEO triggering, and adjusting the TRIGGER LEVEL for a stable trace, the modulation will be displayed in the time domain. (Refer to Figure 37.) The time variation of the modulation signal can then be measured with the calibrated SWEEP TIME/DIV control.

The example shown in Figure 37 demonstrates sinusoidal amplitude modulation, which can be used for narrow-band sine wave testing of components and systems. When the modulation is not a pure sine wave use the HP 8569B to obtain signatures (reference responses) of random modulation for comparison or listen to the VERTICAL OUTPUT with headphones (see Control Glossary). The display can be output to a controller for statistical analysis of random amplitude modulation.

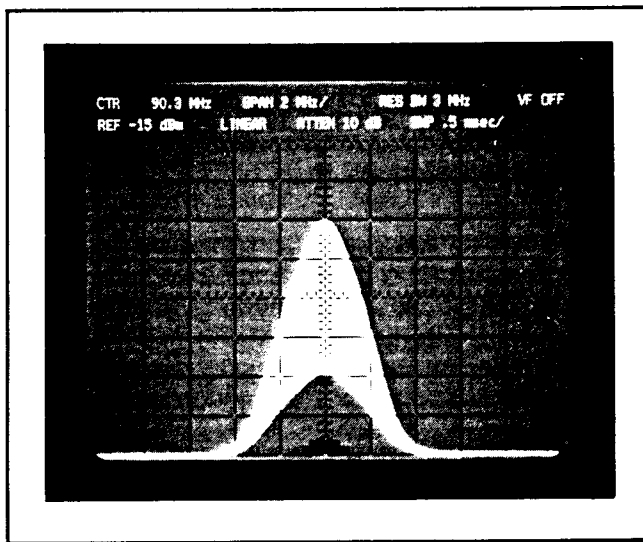

Figure 36. Linear Amplitude Display

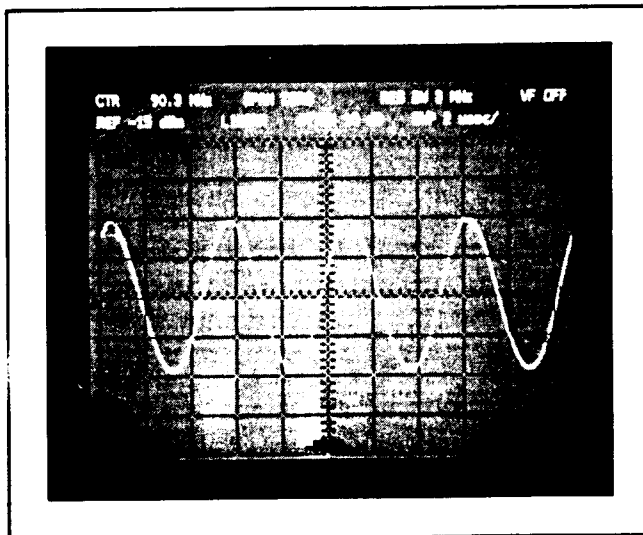

Figure 37. Demodulated AM Signal in ZERO SPAN

## Frequency Modulation

For frequency modulated signals, parameters such as modulation frequency ( $f_m$ ), modulation index ( $m$ ), peak frequency deviation of carrier ( $\Delta f_{\text{peak}}$ ) are all easily measured with the HP 8569B. The FM signal in Figure 38 was adjusted for the carrier null which corresponds to  $m = 2.4$  on the *Bessel* function. The modulation frequency  $f_m$ , is 100 kHz, the frequency separation of the sidebands. The peak frequency deviation of the carrier ( $\Delta f_{\text{peak}}$ ) can be calculated using the following equation:

$$m = \frac{\Delta f_{\text{peak}}}{f_m}$$

$$\text{or } \Delta f_{\text{peak}} = 2.4 \times 100 \text{ kHz} = 240 \text{ kHz}$$

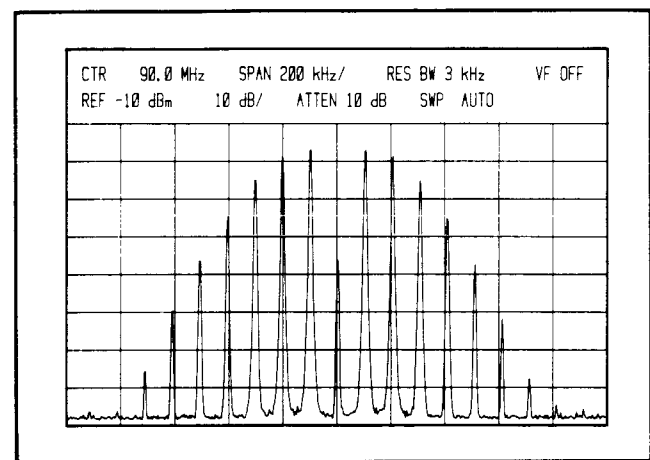

Figure 38. FM Signal

If the FM signal displayed does not correspond to a specific carrier or sideband null, then determination of the modulation index  $m$ , and final calculation of the peak frequency deviation  $\Delta f_{\text{peak}}$ , becomes much more complex and tedious. As with amplitude modulation, the display output can pass to a controller, then, by storing in the controller memory the values of certain analyzer characteristics (such as slope non-linearities of bandwidth filters) and by prompting the user to set certain controls,  $\Delta f_{\text{peak}}$  can be measured directly, or calculated.

Although the HP 8569B does not have a built-in discriminator, FM signals can be demodulated by slope detection. Rather than tuning the signal to the center of the CRT as in AM, the slope of the IF filter is tuned to the center of the CRT. At the slope of the IF filter, the frequency variation is converted to amplitude variation. In FM, the resolution bandwidth must be increased to yield a display similar to that shown in Figure 39 before switching to ZERO SPAN. When ZERO SPAN is selected, the amplitude variation is detected by the analyzer and displayed in the time domain as shown in Figure 40.

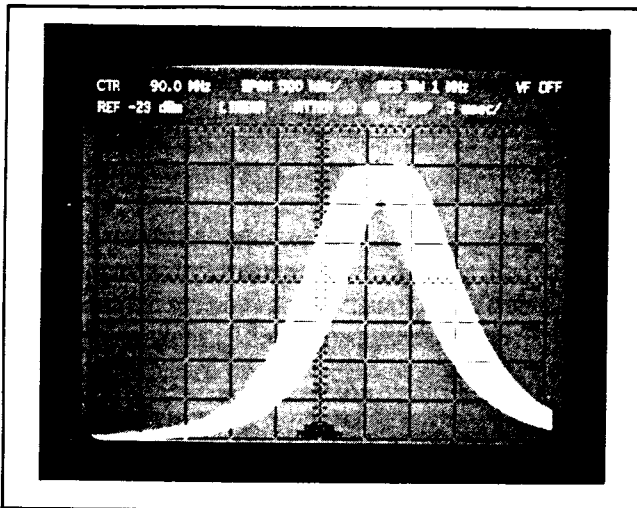

Figure 39. Slope Detection of FM Signal

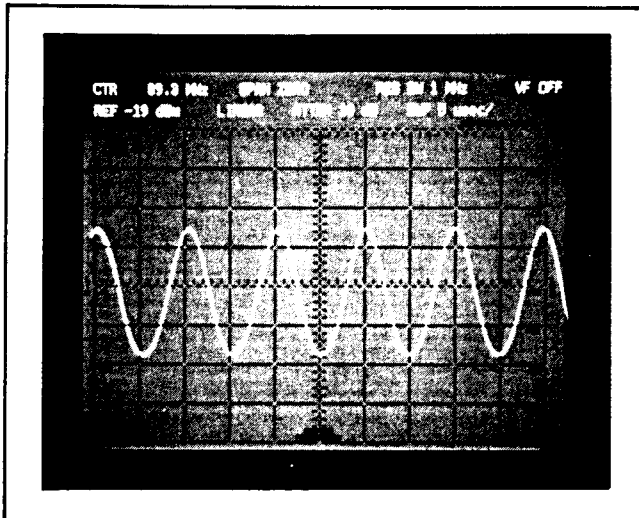

Figure 40. Demodulated FM Signal in ZERO SPAN

### Pulsed RF

A pulsed RF signal is basically an RF signal which is turned on periodically for brief intervals of time. Some parameters to be determined in measuring pulsed RF signals are pulse repetition frequency (PRF), pulse width, duty cycle, on-off ratio of the modulator, and pulse power. Pulse power can refer to either the average power or to the peak power of the pulse.

The spectrum analyzer can display a pulsed RF signal in either of two modes, the line mode or the pulse mode. The factor that determines the display mode is the number of spectral components or lines that are in the passband of the spectrum analyzer at any one time. In the line mode, there is only one spectral component or line in the passband; i.e., the resolution bandwidth is

less than the PRF. In the pulse mode, there is more than one spectral line in the passband; i.e., the resolution bandwidth of the analyzer is greater than about twice the PRF.

Since a spectrum analyzer does not display the actual peak pulse power of the signal (a pulsed signal has its power distributed over a number of spectral components and each component represents a fraction of the peak pulse power), a correction or a desensitization factor must be added to the displayed main lobe power of the pulsed RF signal to obtain the peak pulse power. The calculation of the desensitization factor depends on whether the analyzer is displaying the signal in the line or pulse mode.

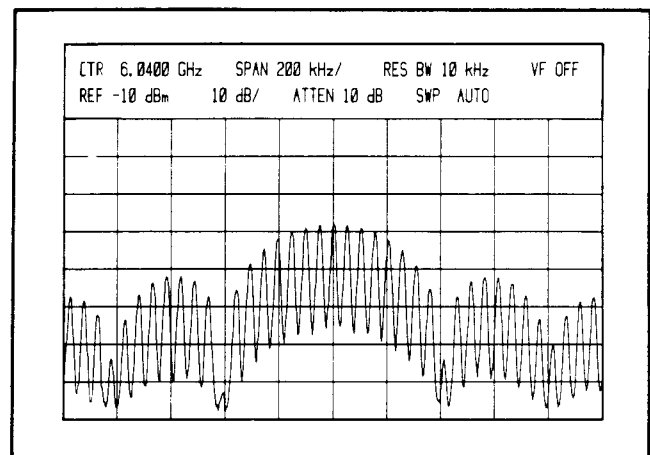

Figure 41. Line Spectrum

### Line Mode

To obtain a *line* spectrum on the analyzer, the resolution bandwidth must be less than the PRF. This ensures that individual spectral lines will be resolved. From the line spectrum shown in Figure 41, it is possible to measure the following parameters:

$$\text{PRF} = 50 \text{ kHz (spacing between spectral lines)}$$

$$\text{Main lobe width} = 800 \text{ kHz}$$

$$\text{Main lobe power} = -38 \text{ dBm}$$

Then, from the above measurement, the following data can be calculated:

$$\begin{aligned} \text{Pulse width} &= \frac{2}{\text{Main Lobe width}} \\ &= \frac{2}{800 \text{ kHz}} = 2.5 \mu\text{sec} \end{aligned}$$

$$\begin{aligned} \text{Duty cycle} &= \frac{2 \text{ PRF}}{\text{Main Lobe width}} \\ &= \frac{2(50 \text{ kHz})}{800 \text{ kHz}} = 0.125 \end{aligned}$$

To determine the peak pulse power in a line spectrum, a pulse desensitization factor ( $\alpha_L$ ) must be added to the measured main lobe power. The desensitization factor is a function of the duty cycle and is represented by the following equation:

$$\alpha_L = 20 \log x \text{ (duty cycle)}$$

For duty cycle of 0.125,  $\alpha_L = -18$  dB. Hence the peak pulse power in Figure 43 is  $-20$  dBm.

### Pulse Mode

To obtain a pulse spectrum on the analyzer, the resolution bandwidth of the analyzer must be set to greater than about twice the PRF, to ensure that more than one spectral line is within the passband of the analyzer. To find the peak pulse power in the pulse mode, add the pulse desensitization  $\alpha_p$ , which is a function of pulse width and spectrum analyzer impulse bandwidth, to the main lobe power.

Figure 44 illustrates a signal in the pulse spectrum mode. As with the line spectrum, the pulse width can be determined from the main lobe width, while the impulse bandwidth is a characteristic of the analyzer.

$$\alpha_p = 20 \log (\text{pulse width} \times \text{Impulse BW})$$

For a pulse width of  $2.5 \mu\text{sec}$  and an impulse bandwidth of  $150 \text{ kHz}$ ,  $\alpha_p = -8$  dB. The peak pulse power of the signal shown in Figure 44 then, is  $-20$  dBm.

A wider resolution bandwidth results when in pulse spectrum mode. The wider resolution bandwidth provides two advantages. First, the signal to noise ratio is increased because the pulse amplitude increases linearly with the resolution bandwidth (BW). The random noise increases proportionally to the square root of the bandwidth ( $\sqrt{\text{BW}}$ ). The only limitation is that the bandwidth should be no greater than about 5 percent of the main lobe width. Secondly, faster sweep times can be used because of the wider resolution bandwidths. The HP 8569B has a 3 MHz resolution BW which enables it to effectively display pulsed RF signals in the pulse mode. The 3 MHz bandwidth, along with fast sweep times, also enables narrow pulse widths to be measured in the time domain. The demodulated pulse signal of Figure 42 is shown in Figure 43.

Few operating pulsed RF systems have ideal spectra. Measurements can still be made regardless of the asymmetry of the spectrum. Examples of non-ideal spectra are found in digital communications and radar.

Since most radar systems do not have ideal spectra, the spectrum of a properly operating system is often stored

away for future reference. This reference or spectral signature can then be used to determine changes that would indicate potential problems. The HP 8569B has the capability of storing display information onto magnetic tape via HP-IB, or by directly plotting the information (hard copy) for use later (refer to Chapter 2).

In digital communications, one major concern is the limits placed on transmissions by regulatory agencies. When the HP 8569B is used with a controller, specification limits can be written directly on the CRT, making conformance testing less tedious.

An additional factor to consider when measuring pulsed RF signals is the VIDEO FILTER control and the digital averaging capability of the spectrum analyzer. In general, the VIDEO FILTER and  DGT L AVG should

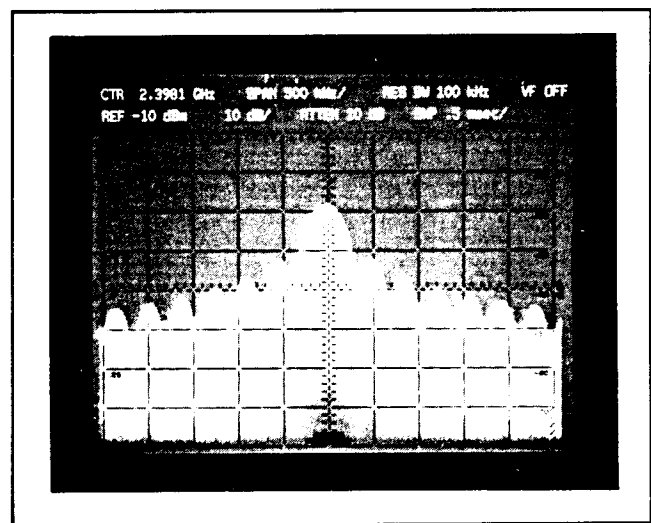

Figure 42. Pulse Spectrum

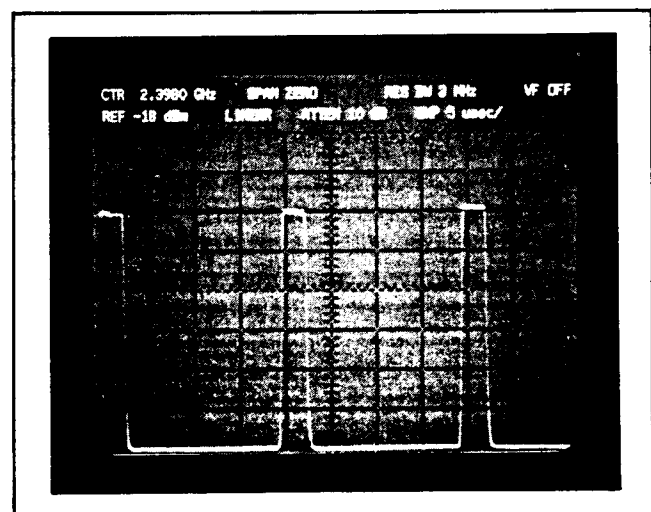

Figure 43. Demodulated Pulsed RF Signal in ZERO SPAN

be OFF when measuring pulsed RF signals. Adding video filtering or digital averaging will desensitize a pulsed signal and limit its displayed amplitude. Therefore, when monitoring pulsed signals in a full-band mode, it is important to use the F mode rather than the FULL BAND pushbutton mode. The FULL BAND pushbutton mode automatically engages a 9 kHz video (0.003 x 3 MHz) filter which will limit the displayed amplitude of the pulse bandwidth.

**NOTE**

**Consult AN 150-2 for more information on pulsed RF measurements.**

**NOISE**

Applications involving noise measurements include oscillator noise (spectral purity), signal to noise ratio, and noise figure. The NOISE AVG position of the VIDEO FILTER control and the digital averaging capability of the spectrum analyzer can be used to measure the analyzer sensitivity or noise power from 0.01 to 22 GHz.

The test setup in Figure 44 is used to make a swept noise figure measurement of an amplifier. First, the total gain of the amplifier under test and the pre-amp is determined. Then, the input of the amplifier is terminated and

its noise power is measured. The noise figure of the amplifier is the theoretical noise power (KTB) minus the total gain plus the amplifier noise power. Figure 45 is a plot of an amplifier's noise power output.

Another technique, called the Y-Factor Technique (refer to Figure 46), overcomes the problems associated with the analyzer's absolute accuracy by using a calibrated noise power standard such as the HP 346B excess noise source. By measuring the ratio of  $P_o$  with the noise source on, to  $P_o$  with noise source off (the test amplifier input terminated in  $Z_o$  impedance), we can determine Noise Figure to a much greater accuracy. Spectrum analyzer instrument errors in the measurement of  $P_o$ . On/ $P_o$ . Off are typically less than a few tenths of a dB, leading to measurement accuracies approaching those of a noise figure meter. Figure 47 shows the results of a Y-Factor measurement.

**NOTE**

**Consult AN 150-4, AN 150-7 and AN 150-9 for more information on noise measurements.**

**ELECTROMAGNETIC INTERFERENCE (EMI)**

The objective of EMI measurements is to ensure compatibility between devices operating in the same vicinity.

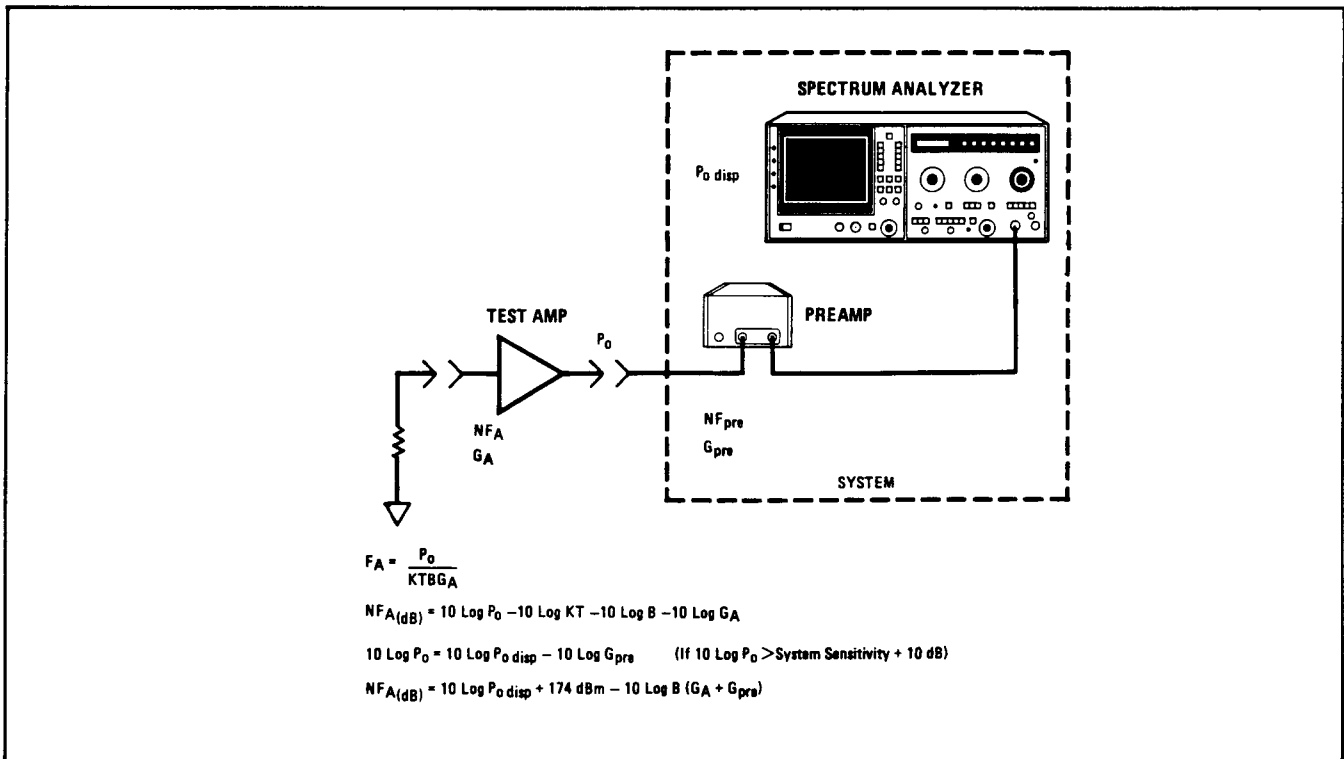

Figure 44. Measuring Noise Figure—Absolute Power Technique

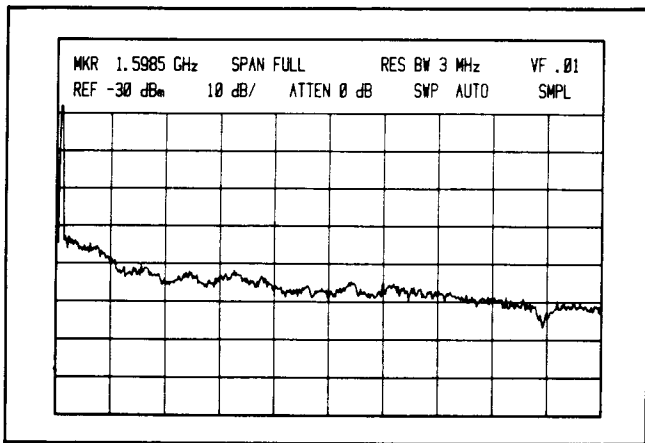

Figure 45. Noise Power Measurement

The HP 8569B, along with an appropriate transducer, is capable of measuring either conducted or radiated EMI and can also be used as a calibration tool for EMI susceptibility testing. Figure 48 illustrates an equipment setup used for measuring radiated field strength.

The antenna in Figure 48 is used to convert the radiated field to a voltage for the analyzer to measure. The field strength is the analyzer reading plus the antenna correction factor. Figure 49 illustrates radiated interference as displayed on the HP 8569B.

Compatibility is also important for high-frequency circuits which are in close proximity to each other. In a multi-stage circuit, parasitic oscillation from one stage can couple to a nearby stage and cause unpredictable

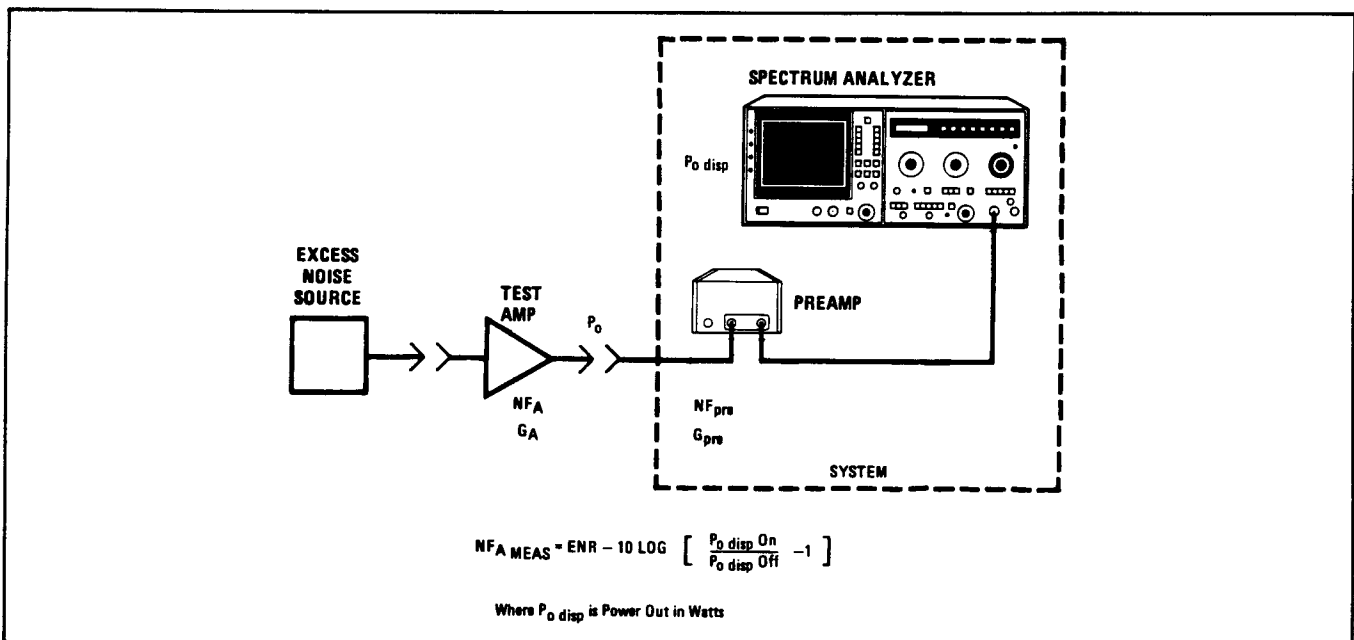

Figure 46. Measuring Noise Figure - Y Factor Technique

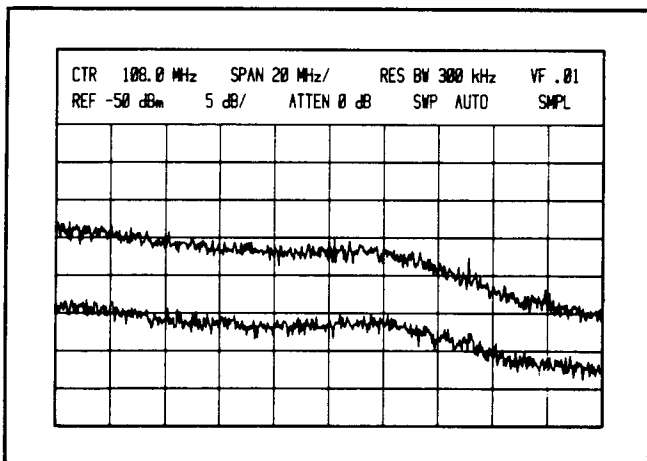

Figure 47. Y-Factor Measurement

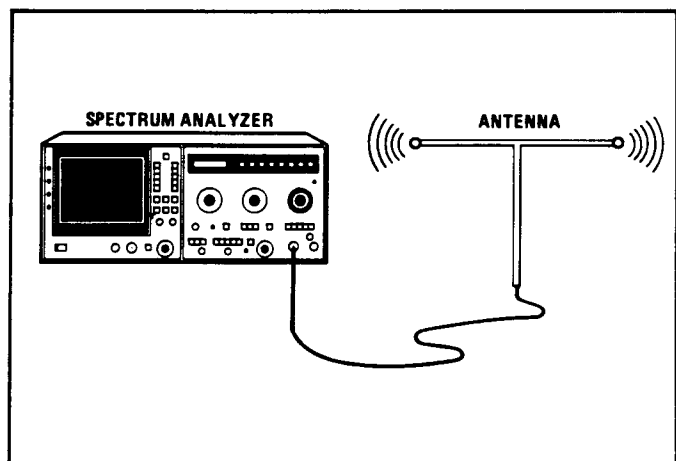

Figure 48. Field Strength Test Setup



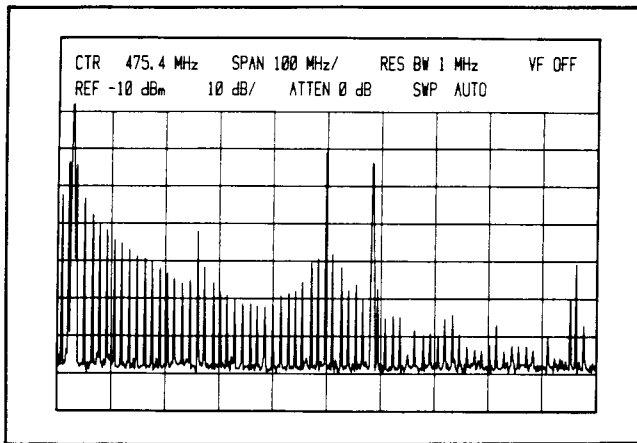

Figure 49. Radiated Interference

behavior. A popular technique used to search for spurious radiation utilizes an inductive loop probe. The loop probe is a few turns of wire that attaches to the spectrum analyzer with a flexible coaxial cable. (Refer to Figure 50.)

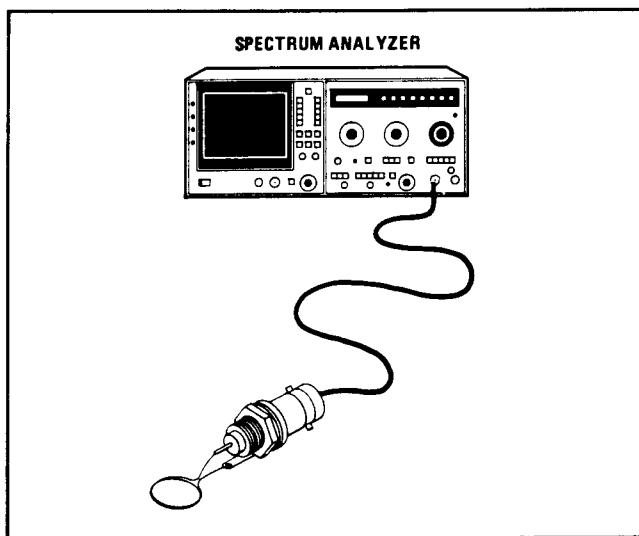

Figure 50. Loop Probe

Various parts of the circuit can be 'probed' to identify the location as well as the frequencies and relative amplitudes of spurious signals. Once the spurious signal has been identified, design techniques can be implemented to reduce or eliminate the cause of interference.

When testing to detailed specifications (i.e. MIL-STD), it is the worst case limits or the peaks of the signals that are of concern.  MAX HOLD can be used to store the maximum amplitudes of these signals for later comparison to specified limits.

With interface to a desktop computer, the HP 8569B spectrum analyzer automatically reformats the display to reflect such test limits as impulse bandwidth normalizations, antenna factor, or current probe corrections.

#### NOTE

Consult AN 150-10 and AN 142 for more information on EMI measurements.

#### SWEPT-FREQUENCY RESPONSE

Frequency response measurements are a common requirement for many system components such as filters, amplifiers, and mixers. The addition of an appropriate source to the spectrum analyzer makes a powerful system for stimulus response (swept-frequency) measurements.

The HP 8444A Option 059 is a tracking generator whose RF output frequency follows (tracks) the tuning of the HP 8569B Spectrum Analyzer over the frequency range of .010 to 1.5 GHz. Since the first local oscillator from the spectrum analyzer is used as a reference by the tracking generator, the low residual FM of the spectrum analyzer is transferred to the tracking generator. The frequency spans of the two instruments are matched and synchronous, providing precise tracking between the two instruments. The equipment setup for this measurement is shown in Figure 51.

A significant advantage of the spectrum analyzer/tracking generator combination for swept measurements is the large dynamic range. The noise is bandwidth limited in the spectrum analyzer, and harmonics and spurious products are not limiting factors since the spectrum analyzer is always tuned to the fundamental of the tracking generator. The dynamic range for the tracking generator and spectrum analyzer extends from the output available on the tracking generator to the noise floor on the analyzer. For the HP 8569B/8444A Option 059 system, the dynamic range is generally greater than 100 dB. Figure 52 illustrates the large dynamic range that is possible using the HP 8444A Option 059 and the HP 8569B.

The system frequency response can be eliminated from the measurement results by using the  INP-B → A mode. First, calibrate the system with a known standard (i.e., a through-line for transmission measurements). Then, store the displayed response in Trace B by using either  STORE VIEW or  STORE BLANK (see Figure 53a). Next, insert device under test, press INP - B → A (see Figure 53b). The displayed frequency response is that of device, not of system plus device (refer to Appendix D concerning position of reference line).

**NOTE**

Errors due to mismatch uncertainty are not removed from measurement by normalization.

The 8444A Option 059 can be used with a counter to make accurate, highly sensitive and very selective frequency measurements of unknown signals. Providing a signal can be resolved on the spectrum analyzer, it can

be counted. The system can count signals down to the sensitivity of the analyzer with the frequency accuracy several orders of magnitude better than the spectrum analyzer accuracy.

**NOTE**

Consult AN 150-3 and AN 150-13 for more information on Swept-Frequency Response measurements.

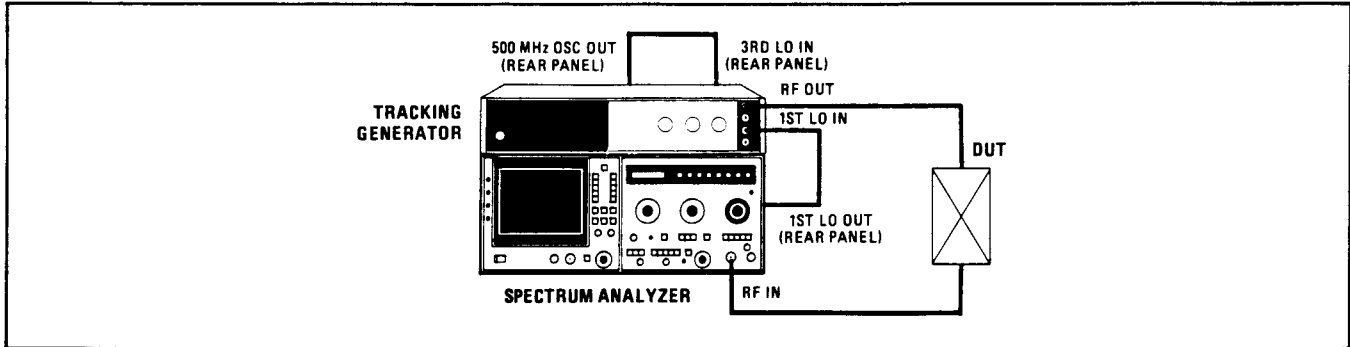

Figure 51. Swept Frequency Response Setup

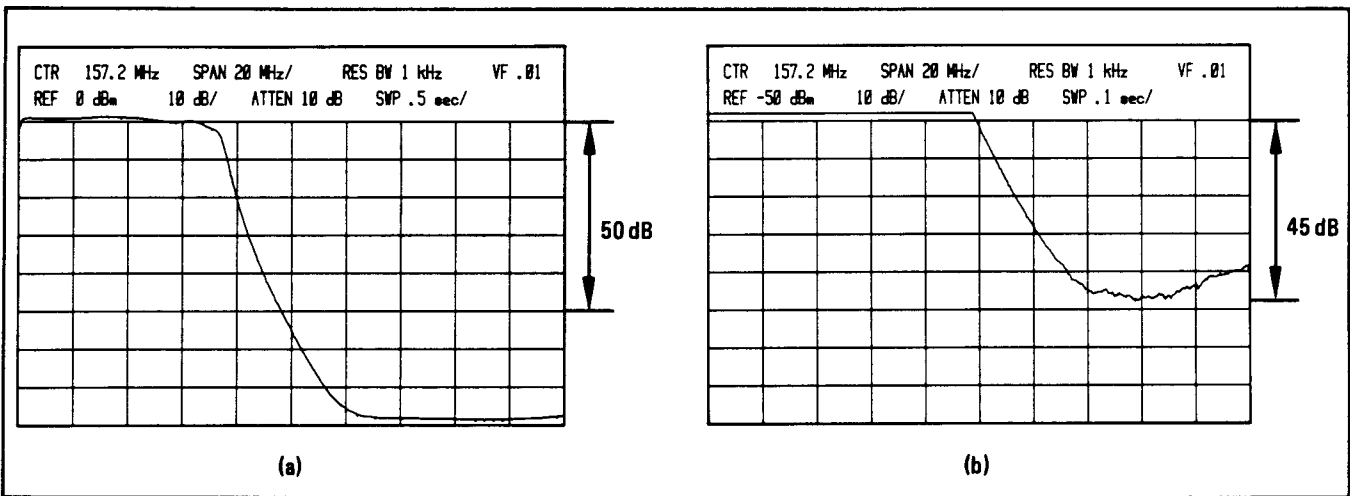

Figure 52. Low Pass Filter Measurement with 95 dB of Rejection

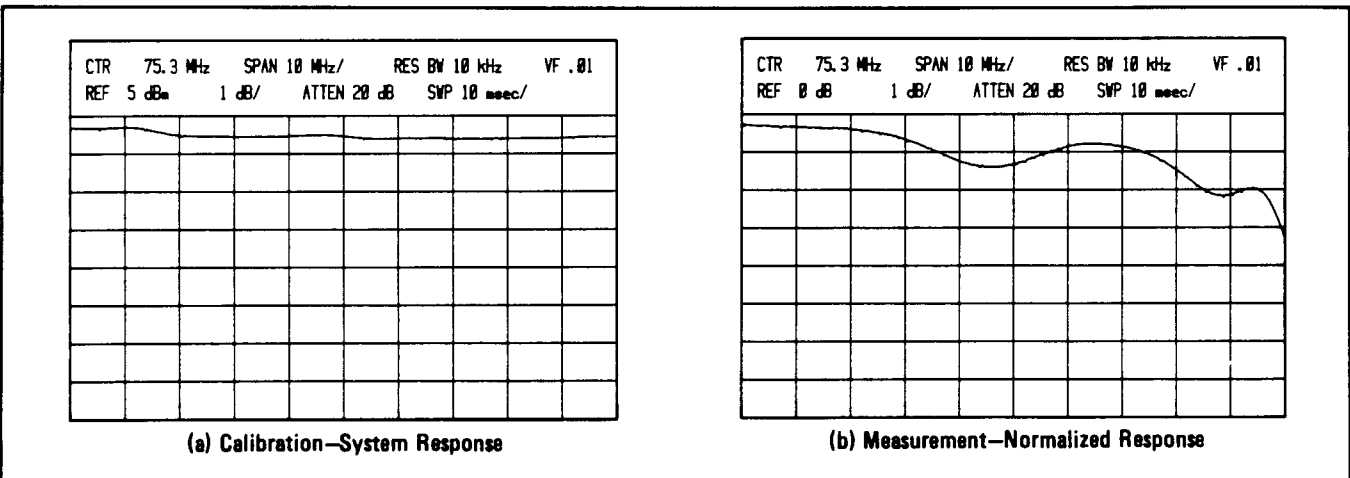

Figure 53. Normalization of Frequency Response

## CHAPTER 5 HP-IB REMOTE OPERATION

This chapter discusses the requirements for remote operation of the spectrum analyzer using an HP-IB<sup>1</sup> controller.

### General Description

The HP 8569B digital storage display and sweep control can be accessed through HP-IB. The HP-IB connector is located on the rear panel (see Figure 54). An HP-IB interconnection cable (often supplied with the HP-IB Interface) is required to connect the analyzer to the controller HP-IB interface.

Programming codes are summarized on the pull-out information card and in Table 5 of this section. A more detailed syntax summary can be found in Appendix E. Programming information dealing with specific HP-IB controllers can be found in the *Introductory Operating Guide* addressing that specific controller.

### HP-IB Compatibility

The complete bus capability of the spectrum analyzer as defined in IEEE STD 488 (or the identical ANSI Standard MC 1.1), is presented following Table 6. The pro-

<sup>1</sup>Hewlett-Packard Interface Bus, the Hewlett-Packard implementation of IEEE STD 488-1975 and ANSI STD, MC 1.1, "Digital Interface for Programmable Instrumentation."

gramming capability of the instrument is further described by the three HP-IB messages in Table 6. Foremost among these messages is the data message, which is the primary method of communication between the analyzer and the controller. The responses of the analyzer to other messages are shown as well.

### Addressing the Spectrum Analyzer

Communication between instruments on the HP-IB requires that a unique address be assigned to each instrument. The address switch (Figure 55) on the rear panel of the analyzer is used to set the analyzer address.

The instrument address is the binary number represented by the on (1) or off (0) states of the five switch segments (A1 through A5). For example, the address 18 is set when A2 and A5 are on (1) and the other switch segments are off (0).

### Digital CRT Display Coordinates

References to the CRT display coordinates (specifically, commands AP/BP, BA/BB, IA/IB, and TA/TB as listed in Table 5) will follow the layout in Figure 56.

Within the range of the graticule, there are a total of 481 X-axis values (0 to 480, with 48 points per division) and 801 Y-axis values (0 to 800, with 100 points per division).

*Table 5. HP-IB Programming Codes*

<b>HP-IB Commands (Alphabetical Listing)</b>			
<b>AL</b>	Display lower line control settings	<b>LL</b>	Input lower line message
<b>AP</b>	Output trace A peak signal coordinates	<b>LU</b>	Input upper line message
<b>AT</b>	Output RF Input Attenuation	<b>MS</b>	Output value of sweep flag
<b>AU</b>	Display upper line control settings	<b>NS</b>	Output INP-B→A state
<b>BA</b>	Output trace A byte values	<b>RB</b>	Output Resolution Bandwidth
<b>BB</b>	Output trace B byte values	<b>RL</b>	Output Reference Level
<b>BP</b>	Output trace B peak signal coordinates	<b>SF</b>	Start sweep and set sweep flag
<b>CF</b>	Output Center Frequency	<b>SP</b>	Output Frequency Span/Div
<b>CS</b>	Output annotation	<b>ST</b>	Output Sweep Time
<b>DG</b>	Output display mode	<b>TA</b>	Output trace A integer values
<b>DM</b>	Output detection mode	<b>TB</b>	Output trace B integer values
<b>IA</b>	Input trace A integer values	<b>TS</b>	Take sweep
<b>IB</b>	Input trace B integer values	<b>VF</b>	Output Video Filter
<b>LG</b>	Output Amplitude Scale		

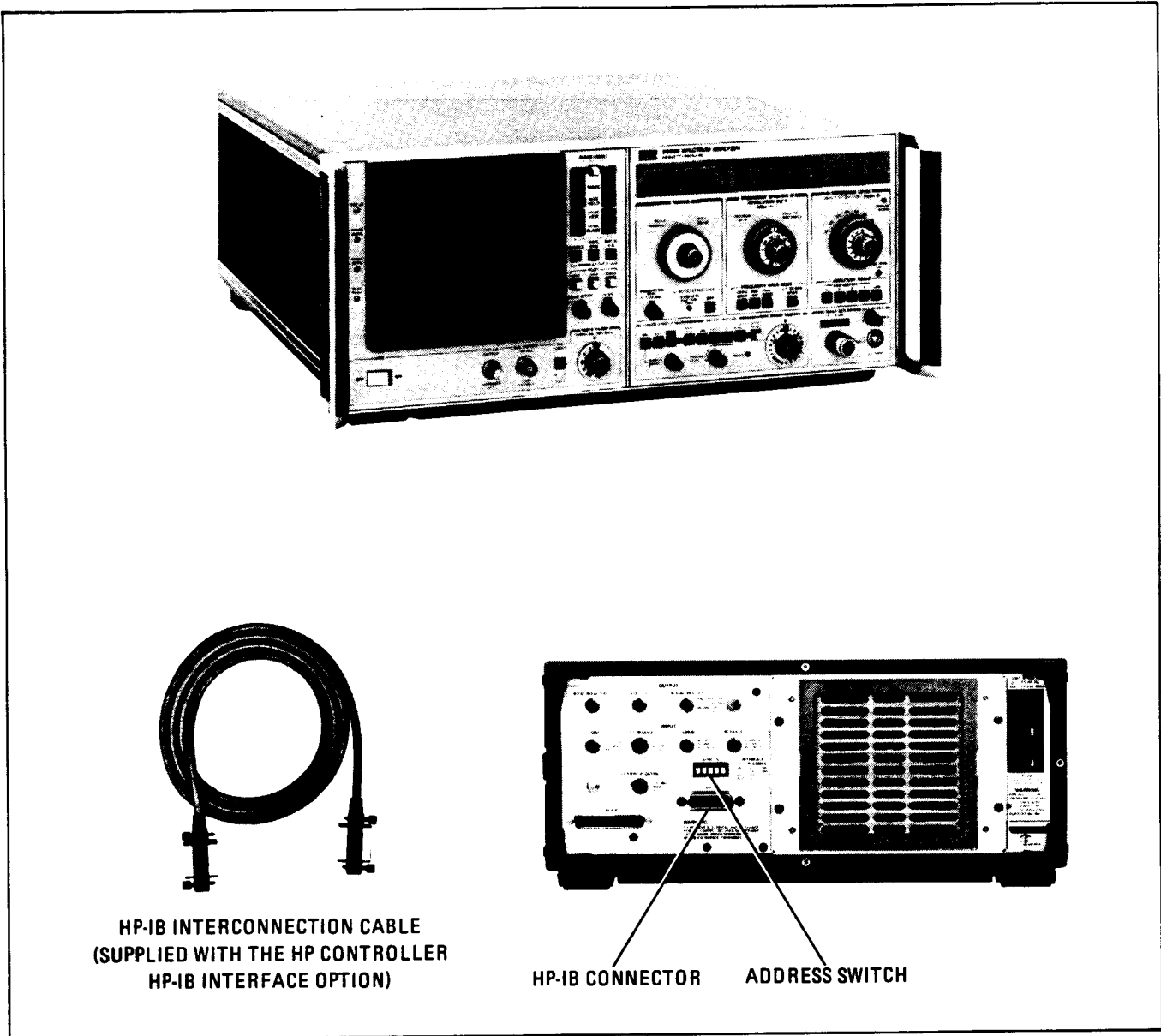

Figure 54. HP 8569B with HP-IB Interconnect Cable

The Y-axis overrange values displayed above the top of the graticule are 801 to 820 for the trace output commands AP/BP, BA/BB, and TA/TB and 801 to 975 for the trace input commands IA/IB. (Values above 950 may be deflected off the top of the screen.)

Two lines of annotation near the top of the CRT display are controlled by the labeling commands CS, LL/LU, and AL/AU.

Table 5 is a summary of the HP 8569B HP-IB Programming Codes. For more detailed information concerning the front-panel controls of the analyzer, refer to Chapter 2. For information on syntax requirements, refer to Appendix E.

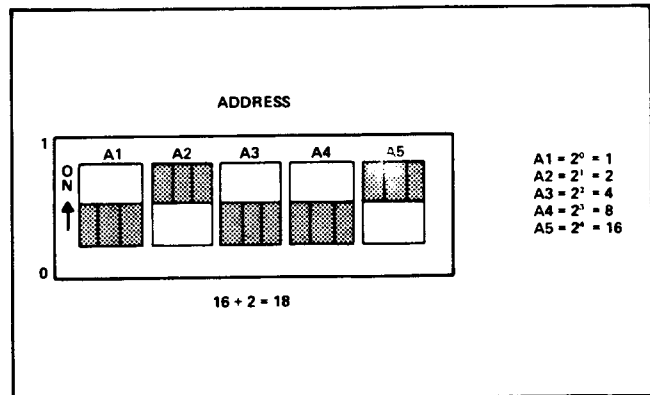

Figure 55. HP-IB Address Switch

Table 6. HP-IB Message Reference Table

HP-IB Message	Response	Related Commands and Controls*	Interface Functions*
Data	Information pertaining to the digital storage display is available to the bus. Trace data and display messages can be sent to the analyzer via HP-IB. Program instructions can initiate sweeps.		T7, L4 AH1, SH1
Clear	Device clear; clear active traces and reset sweep.	DCL SDC	DC1
Abort	Interface clear; unaddress instrument.	IFC	T7, L4

\*Commands, Control lines and Interface Functions are defined in IEEE STD 488 (and the identical ANSI Standard MC1.1). Complete HP-IB capability is: SH1, AH1, T7, TE0, L4, LE0, SR0, RL0, PP0, DC1, DT0, C0, E2.

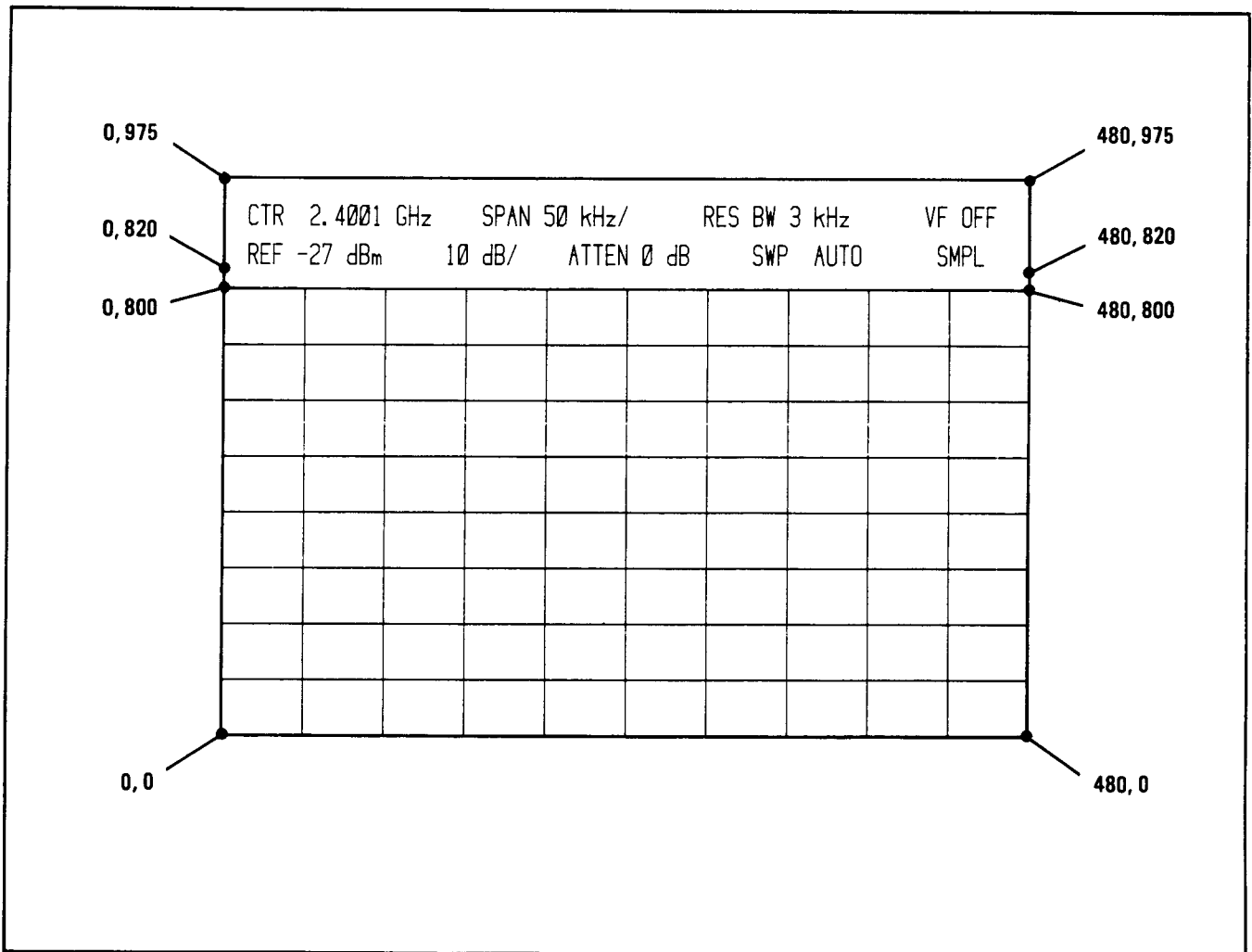

Figure 56. Display Coordinates

## APPENDIX A OPERATING PRECAUTIONS

### WARNING

**This instrument and any device connected to it must be connected to power line ground. Failure to ensure proper grounding may cause a shock hazard to personnel or damage to the instrument.**

The spectrum analyzer is a sensitive measuring instrument. To avoid damage to the instrument, do not exceed the following **absolute maximum input levels**:

- Total RF power: + 30 dBm (1 watt)
- dc or ac ( $\ll 50\Omega$  source impedance):
  - 0V with 0 dB input attenuation (<1 amp);  $\pm 7V$  with  $\geq 10$  dB input attenuation (<0.14 amp).
- Peak pulse power: + 50 dBm (<10  $\mu$ sec pulse width, 0.01% duty cycle) with  $\geq 20$  dB attenuation.

### NOTE

**Overdriving the input with too much power, either peak or dc voltages, might damage the input circuit and require expensive repairs.**

If large dc components are present with ac signals, a blocking capacitor should be used at the INPUT of the analyzer to eliminate the dc components.

### LOW IMPEDANCE AC

A source with much less than  $50\Omega$  nominal output impedance can produce excessive current which might damage the input circuit of the analyzer.

### DC PRECAUTIONS

The HP 8569B *cannot* accept dc voltages in 0 dB INPUT ATTEN. With 10 dB or greater INPUT ATTEN, small dc voltages ( $< \pm 7V$ ) can be accepted without damage if the total power (ac and dc) does not exceed 1 watt.

The input is direct-coupled and its dc input resistance varies from 0 to  $87\Omega$ , depending on the settings of INPUT ATTEN and FREQUENCY BAND GHz controls. (See Figure A-1.)

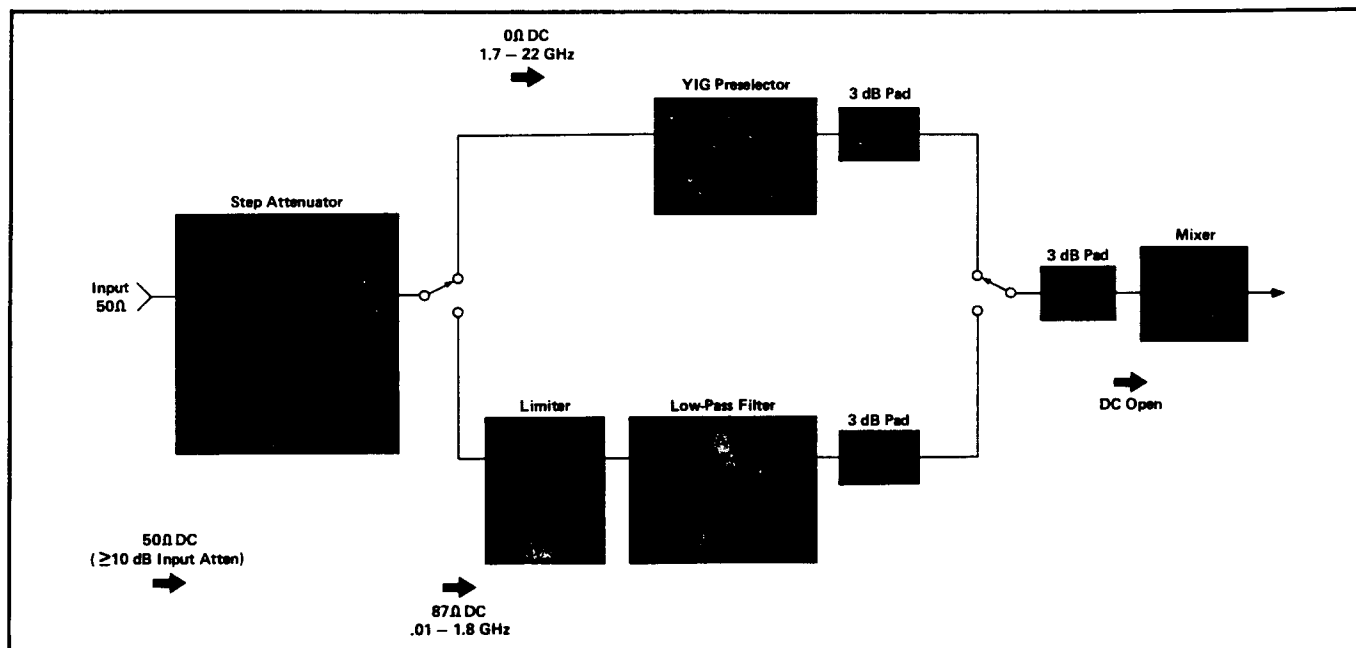

Figure A-1. DC Block Diagram

## APPENDIX B THEORY OF OPERATION

### SYSTEM DESCRIPTION

The HP Model 8569B Spectrum Analyzer is basically an electronically swept superheterodyne receiver. It has high sensitivity and selectivity, a wide, distortion-free dynamic range, and excellent flatness from 10 MHz to 22 GHz. With external mixing, frequency coverage can be extended up to 115 GHz. The HP 8569B consists of an RF and an IF section, an automatic stabilization and control section, and a digital storage display section. These sections will be discussed separately in this appendix. Figure B-1 is a simplified block diagram of the instrument.

### RF SECTION

The RF section is composed of a 0–70 dB step attenuator, an automatic preselector, a tunable local oscillator (LO), and a broadband mixer. The step attenuator at the input to the spectrum analyzer is used to control the signal level to the mixer for optimum dynamic range and signal-to-noise ratio. The automatic preselector consists of a low-pass filter from 0.01 to 1.8 GHz and a yttrium-iron-garnet (YIG) tuned filter (YTF) from 1.7 to 22 GHz. Coaxial RF switches are used to switch to the proper filter, depending on the selected frequency band. The automatic preselector greatly reduces most image, multiple, and spurious responses of the analyzer and thus enhances its dynamic range. A transistorized YIG-tuned oscillator (YTO) with a fundamental tuning range of 2.05 to 4.46 GHz is used as the LO in this superheterodyne system.

The basic frequency conversion equation for a heterodyne system is given in equation 1:

$$F_s = F_{LO} \pm F_{IF} \quad (1)$$

where:

$F_s$  = signal frequency

$F_{LO}$  = local oscillator frequency

$F_{IF}$  = intermediate frequency

The main IF in the HP 8569B is set at 321.4 MHz, and the first LO sweeps from 2.0 to 4.46 GHz. Therefore, from equation 1,  $F_s$  would cover approximately 1.68 to 4.14 GHz in fundamental operation. With harmonic mixing, the frequency range is extended to 115 GHz, as shown in equation 2:

$$F_s = NF_{LO} \pm F_{IF} \quad (2)$$

where:

$$N(\text{harmonic number}) = 1-, 2-, 3-, 4+, 5+, 6+, 10+, 16+, 26+$$

Each harmonic number creates a tuning curve, illustrated in Figure B-2. Signal frequencies from 0.01 to 1.8 and 1.7 to 22 GHz are converted by the broadband internal mixer to a 2050 MHz IF and a 321.4 MHz IF, respectively. In the 1.7 to 22 GHz frequency range, the YIG-tuned filter tracks a particular tuning curve and thus eliminates spurious responses resulting from harmonic mixing. From 14.5 to 115 GHz, an external waveguide mixer is used to convert the input signals to a 321.4 MHz IF, which is then further processed by the analyzer.

### AUTOMATIC STABILIZATION SECTION

Many factors can limit the resolution of the spectrum analyzer. Among these are the stability and spectral purity of the local oscillator and the bandwidth and shape factor of the IF filter. Of these limitations, the most significant for microwave analyzers is usually the stability (residual FM or drift) of an oscillator. For this reason, the HP 8569B utilizes an automatic stabilization circuit that locks the YTO to a 1 MHz crystal reference oscillator. The lock is automatically engaged when frequency spans of 100 kHz/Div or less are selected. The AUTO STABILIZER can be disabled by a push button switch located on the front panel. An added feature of the automatic stabilization circuit is the use of offset compensation to keep the signal of interest fixed on the CRT during stabilization. The circuit is designed so that the YTO is not moved when it is locked to the reference oscillator. Since there is no frequency shift in the YTO, there is no shift in the displayed signal. This eliminates the need for the user to retune the signal on the CRT once the instrument has been stabilized.

## IF SECTION

The IF section consists of components in the signal path after the first mixer. The output from the first mixer is either 2050 MHz (for the .01 to 1.8 GHz band), or 321.4 MHz (for all other bands). Signals at 321.4 MHz bypass the second converter, whereas a 2050 MHz signal would mix with the second LO at 1.7286 GHz to also produce a 321.4 MHz IF. At the third converter, the 321.4 MHz IF is amplified, filtered, and mixed with the third LO at 300 MHz to produce a final IF of 21.4 MHz. The output of the third converter goes to a variable gain amplifier, selectable bandpass filters, variable gain logarithmic amplifiers, and linear amplifiers. It is then detected. The detected video signal goes through a selectable video filter before it is sent to the display for digital processing. The IF bandpass filter, log and linear amplifiers, and video filter are all controllable from the front panel of the spectrum analyzer.

## DIGITAL STORAGE DISPLAY

The Digital Storage Display section performs two major functions. The first, which is controlled by the CPU (Central Processing Unit), is to acquire, process, and store display data in memory (referred to as Stroke Memory). The second, which is controlled by the counter, is to retrieve data from stroke memory and to display it on the CRT.

Since the CPU can process only digital information, an Analog to Digital Converter is provided to convert analog signals to digital information. The rate at which data is acquired varies with the instrument sweep speed, which is set by the Sweep Generator. During normal operation, the CPU alternately takes samples of the horizontal and vertical signals; the horizontal (X) value determines the memory address at which the vertical (Y) value is stored.

The counter accesses Stroke Memory and transfers the acquired data into the Y Data Buffer. Control logic determines the time at which the Y Data Buffer will transfer its data to the Digital Y Generator, which converts the retrieved data to an analog voltage that is applied through the Y Amplifier to the vertical deflection plates of the CRT. The horizontal (X) signal is generated by the Digital X Generator. The Digital X Generator receives control signals, derived from the counter, and generates an appropriate ramp voltage that is amplified and applied to the horizontal deflection plates of the CRT.

The Z-Axis signal controls both the brightness and the blanking of the trace. The Digital Y Generator outputs stroke length information, which is then converted to a brightness signal. The signal is used so that long strokes will not be dimmer than short ones. All remaining blanking inputs and control logic inputs are combined to produce one blanking signal that controls the blanking of the CRT. Generation of the display characters, seen on the top portion of the CRT, is accomplished by the Character Generator (addressed by the Counter and Data Bus) and by the blanking circuitry.

The Digital Storage Display section also performs secondary functions that are integral to the operation of the instrument but are not necessarily involved with acquisition and display of X and Y signals.

Secondary functions performed by the CPU (with the Input/Output Interface) include response to display control push buttons, interpretation of instrument control switches, and operation of the HP-IB Interface. The CPU also plays a major role in the performance of an automatic internal instrument check routine, as well as other test routines that are used to adjust, verify correct operation, and troubleshoot the digital storage circuitry. (Refer to the HP 8569B Operation and Service Manual, Section VIII.)

## TUNING CONTROL SECTION

The Tuning Control Section contains the Frequency Control, YIG Driver, Frequency Display Unit, Sweep Attenuator, and Sweep Generator.

The Sweep Generator provides a sweep voltage that is simultaneously applied to the horizontal (X) deflection amplifier, data converter, and sweep attenuator. The sweep attenuator, controlled by the FREQUENCY SPAN/DIV control, reduces the sweep voltage to the Frequency Control Unit to maintain a calibrated horizontal scale on the CRT. In addition, the tuning control voltage, which sets the center frequency of the analyzer, is also applied to the Frequency Control Unit, where it is summed with the attenuated sweep. The resultant signal is then applied to the YIG oscillator drivers. Both the YTF and the YTO have separate YIG oscillator drivers which are basically voltage-to-current converters. A pre-selector peak adjustment is used to control the offset of the YTF YIG driver circuit. It is adjusted to eliminate any amplitude uncertainty due to nonlinear tracking between the YTF and the YTO. The Frequency Display Unit displays the frequency represented by the center of the CRT display.



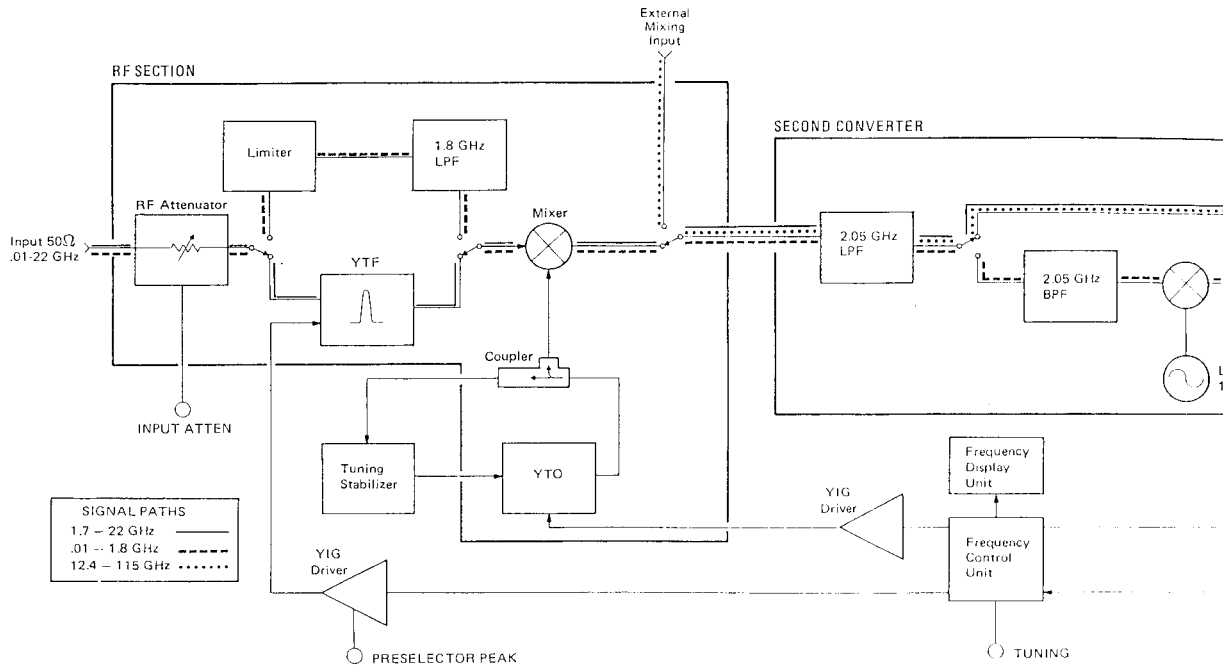

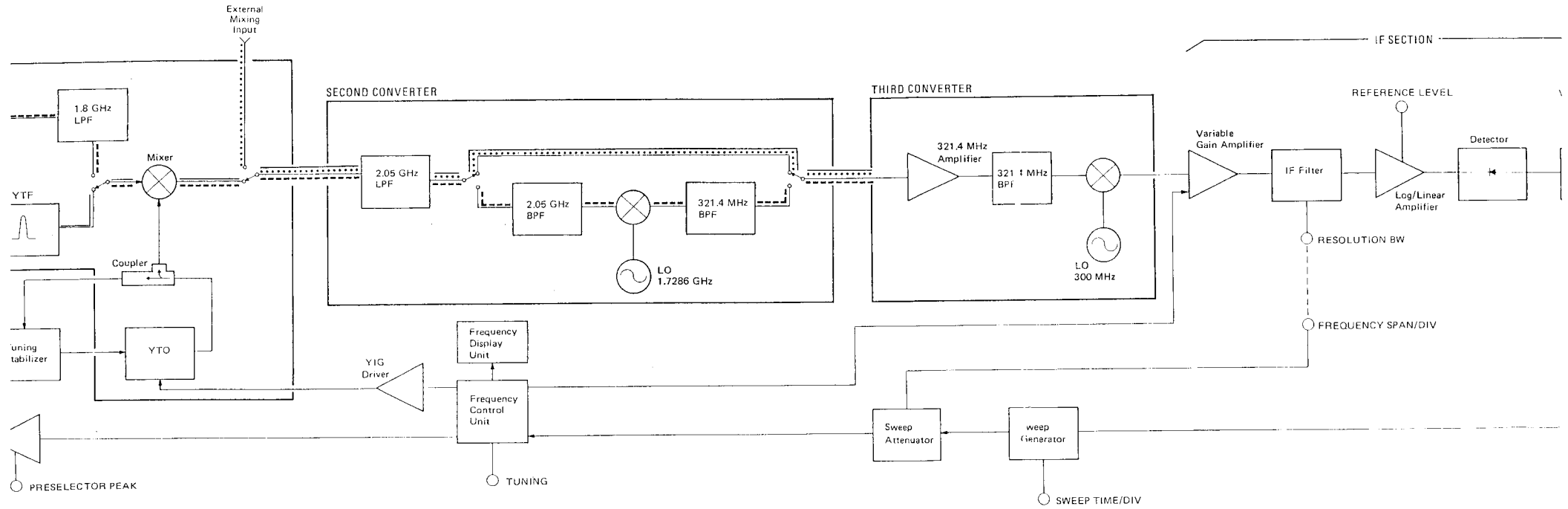

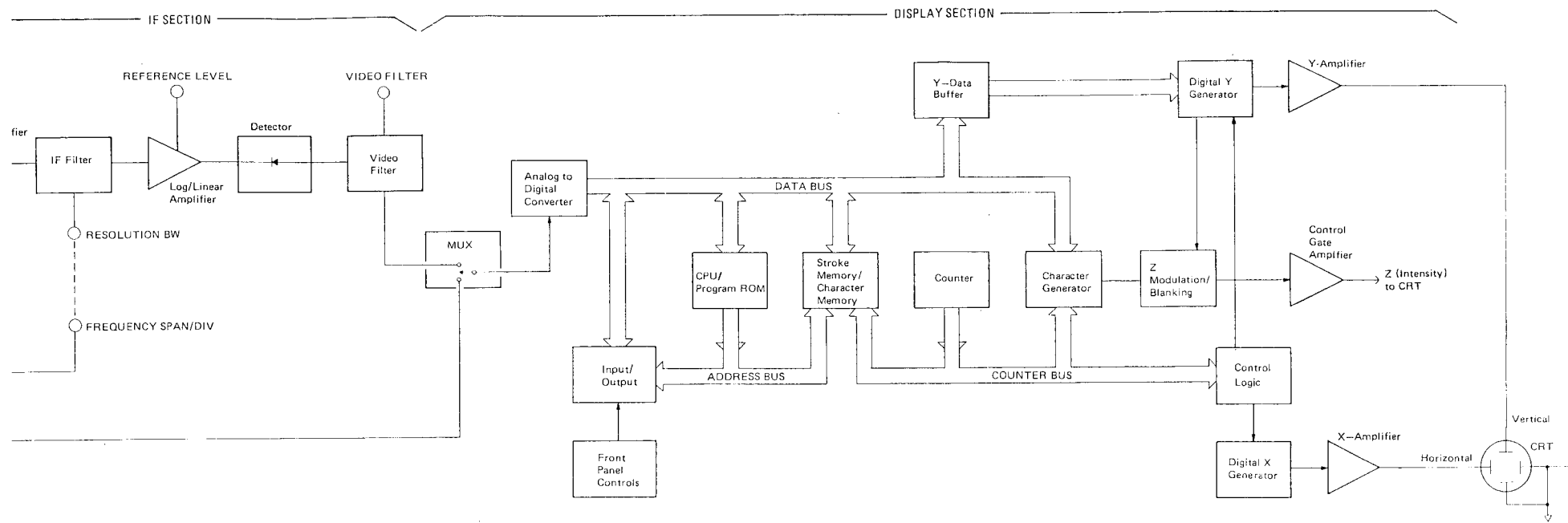

Figure B-1. HP 8569B Block Diagram

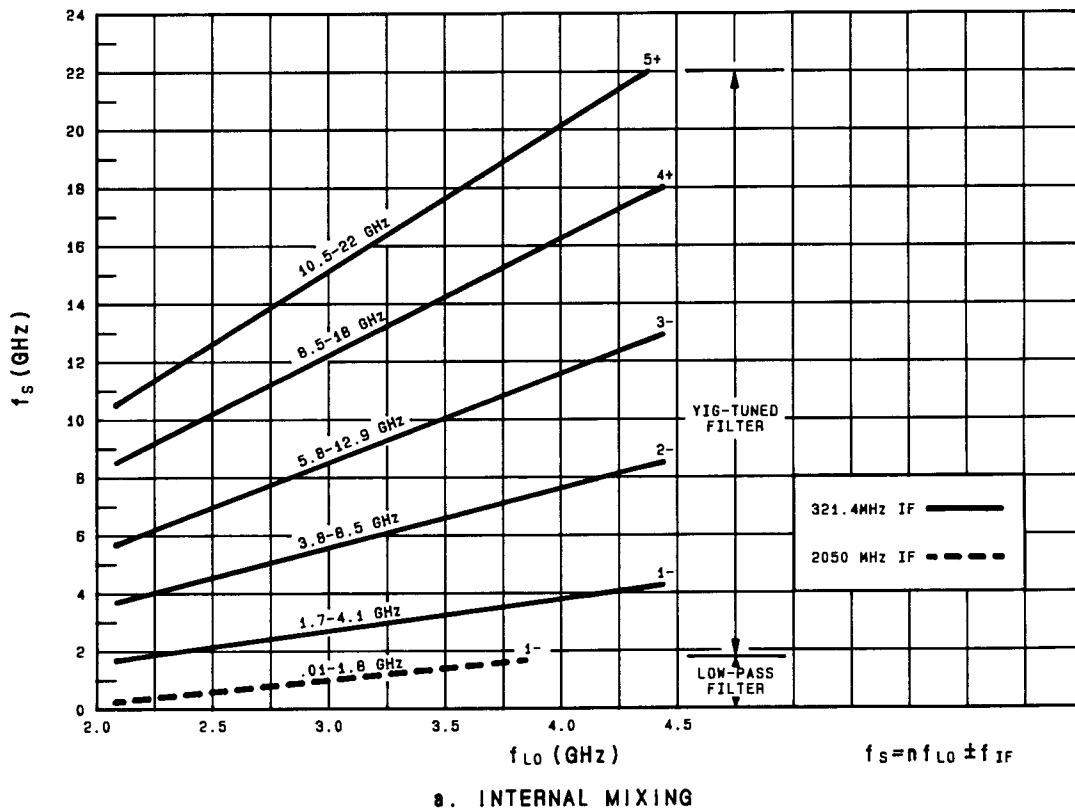
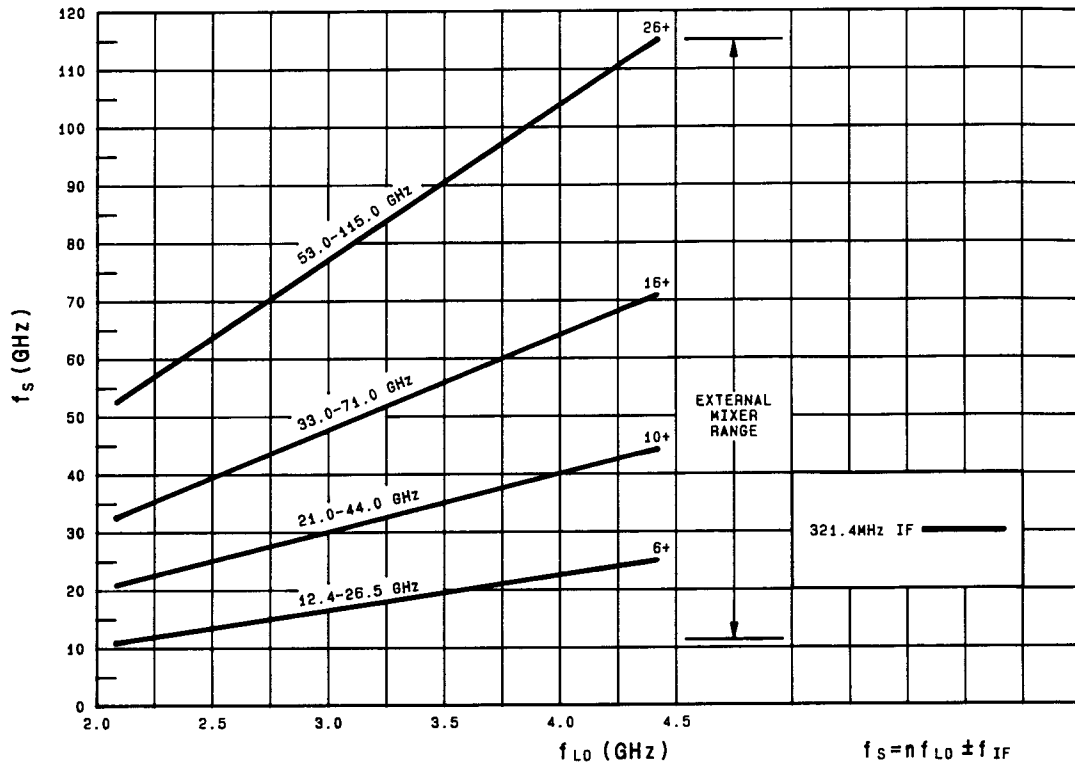

Figure B-2. HP 8569B Tuning Curves

## APPENDIX C AMPLITUDE CONVERSIONS

The HP Model 8569B Spectrum Analyzer reads signal levels in dBm. The following equations allow conversion from dBm to dBmV or dBV in a 50Ω system.

### CONVERSION EQUATIONS

$$\text{dBm} + 107 \text{ dB} = \text{dB}\mu\text{V}$$

$$\text{dBm} + 47 \text{ dB} = \text{dBmV}$$

$$\text{dBmV} + 60 \text{ dB} = \text{dBV}$$

If it is desired to convert from logarithmic units to linear units, then the equations given below will be useful. Keep in mind that the logarithmic levels are all referenced to linear units.

That is:

- 0 dBm referenced to 1 mW
- 0 dBmV referenced to 1 mV
- 0 dBμV referenced to 1 μV

To calculate a linear level, simply take the antilog of the logarithmic level.

$$\text{dBm to } P(\text{mW})$$

$$\text{dBm} = 10 \log \frac{P}{1 \text{ mW}}, P = \log^{-1} \frac{\text{dBm}}{10}$$

$$\text{dBmV to } V(\text{mV})$$

$$\text{dBmV} = 20 \log \frac{V}{1 \text{ mV}}, V = \log^{-1} \frac{\text{dBmV}}{20}$$

$$\text{dB}\mu\text{V to } V(\mu\text{V})$$

$$\text{dB}\mu\text{V} = 20 \log \frac{V}{1 \mu\text{V}}, V = \log^{-1} \frac{\text{dB}\mu\text{V}}{20}$$

Figure C-1 can be used to convert from dBm to voltage in a 50Ω system.

Conversion from dBm to volts can be made whether the AMPLITUDE SCALE is in LOG or LINEar. To read voltage on the HP 8569B, position the signal on the REFERENCE LEVEL line of the CRT. Read the REF LEVEL in dBm and find its equivalent voltage from the conversion chart (Figure C-1). The REF LEVEL calibration can be changed from dBm to dBμV by means of an internal jumper (Appendix D).

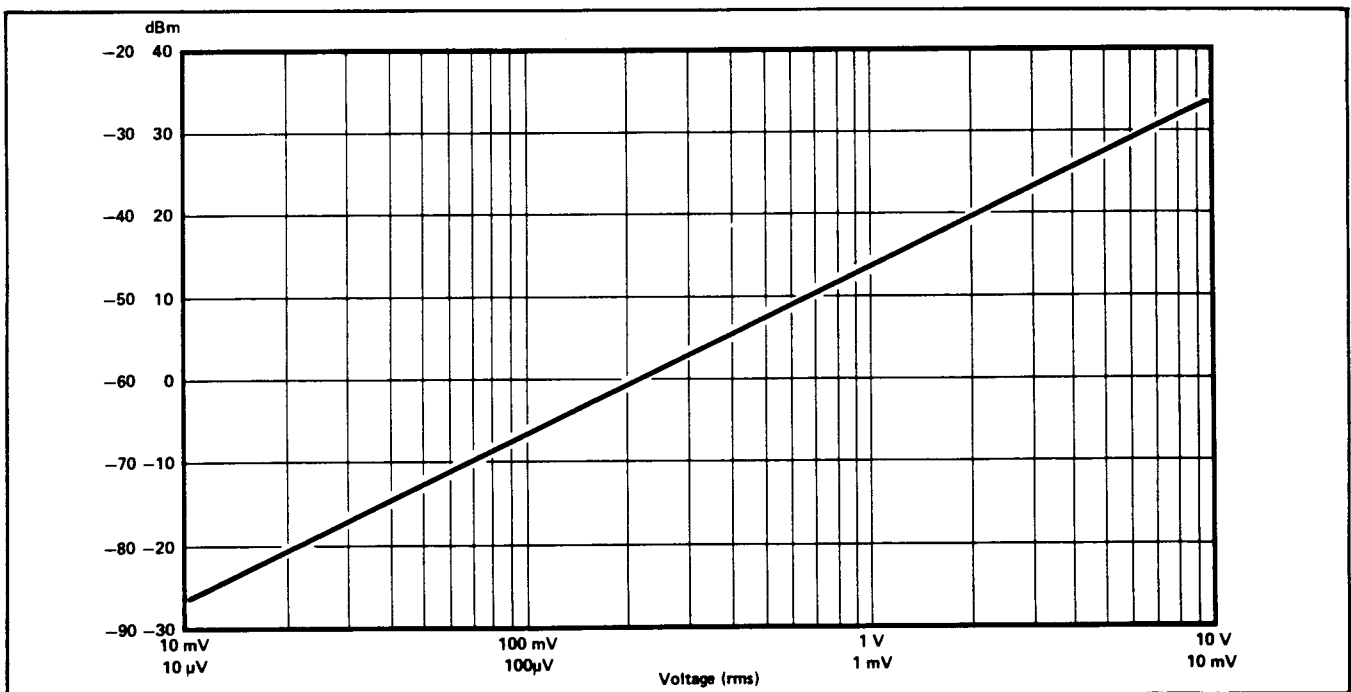

Figure C-1. Conversion Chart - Converts from dBm to Voltage in 50Ω

## APPENDIX D OPTION STATUS INTERFACE

Certain options on the HP 8569B can be enabled by means of a single jumper per option.

The jumper socket (J2) is part of the Option Status Interface, located on the A7 Input/Output Assembly. A diagram showing the location of J2 is shown in Figure D-1.

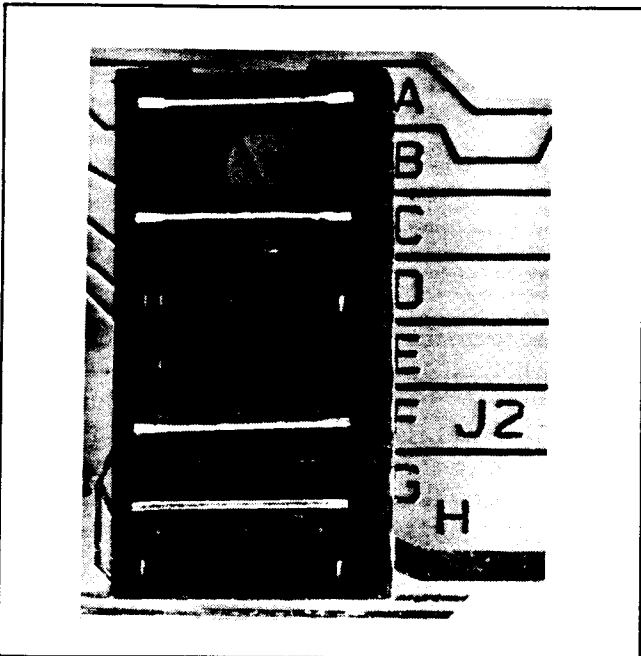

Figure D-1. Option Status Jumpers

### WARNING

Positioning of the option jumpers requires working on the instrument with protective covers removed and should be done only by a qualified service techni-

**cian who is aware of the potential shock hazard. To avoid electrical shock, the line (mains) power cable should be disconnected before removing the protective covers from the spectrum analyzer.**

Four (4) options are available on the OPTION STATUS INTERFACE.

1. Minimum Resolution Bandwidth  
Pin A to Pin 1 (100 Hz Bandwidth)\*  
Pin B to Pin 2 (1 kHz Bandwidth)

### NOTE

**The Minimum Resolution Bandwidth option is not usable with Option 002 instruments.**

2. Display Units – Reference Level  
Pin C to Pin 3 (dBm)\*  
Pin D to Pin 4 (dB $\mu$ V)
3. Display Resolution – Center Frequency  
Pin E to Pin 5 (100 kHz)\*  
Pin F to Pin 6 (1 MHz)
4. Reference Position for Normalized Response (INP – B→A)  
Pin G to Pin 7\*  
(Center Horizontal Graticule Line)  
Pin H to Pin 8  
(Top Horizontal Graticule Line)

\*No connection needed, default condition.

## APPENDIX E SYNTAX REFERENCE GUIDE

This Syntax Reference Guide is intended to provide, in detail, the required forms of command to be used when addressing the analyzer from an external HP-IB controller, and to describe precisely the resulting HP-IB output from the analyzer. It is important to keep in mind that this guide is written from a controller point of view, as user-generated programs will always be executed in the controller, not in the spectrum analyzer.

A pictorial flow representation is used to delineate the sequence of bytes or blocks of traffic across the bus. Literal ASCII characters are bold and shown in rounded envelopes. These are transmitted exactly as shown. Items enclosed by rectangular boxes are blocks of bus traffic which require further explanation. Those used repeatedly are described immediately below; others are dealt with on a command by command basis.

**Output** UNL TA21 LA18: UNListen, Talk Address 21, Listen Address 18 (analyzer factory-set select code=18) (ASCII code: ?U2)

**Enter** UNL LA21 TA18: UNListen, Listen Address 21, Talk Address 18 (ASCII code: ?5R)

**Additional Commands** Additional analyzer commands (two letter mnemonics) may follow within the same "Output" statement

Note that data bytes passed across the bus originate from the controller (controller is talker) until an "Enter" block is transmitted at which time the analyzer generates any succeeding data (analyzer is talker).

In several cases, two commands are used in an identical fashion and are listed together. Each pair performs the same function either on lower or upper lines of text (e.g., AL and AU) or on Trace A or Trace B (e.g., AP and BP). Only the usage of the first command listed is described; the second command may simply be substituted in its place.

A reference in a command description to a "digit" should be understood to be the ASCII code for the character 1, 2, 3, 4, 5, 6, 7, 8, 9, or 0.

The analyzer is able to ignore extra delimiters such as **C<sub>R</sub>** (carriage return) and **L<sub>F</sub>** (linefeed) at several points in a command sequence to the analyzer. On the other hand,

every byte indicated as output from the analyzer, i.e., data which immediately follows an "Enter" block, must be read by the controller or the analyzer will not be able to resume normal operation.

All commands which return values to the controller, except for the binary transfer commands, BA, BB, and MS, are terminated by transmitting an LF with the interface bus line EOI (End or Identify) pulled true. The commands BA, BB, and MS send no terminating LF, but the EOI line is pulled true during transmission of the final byte of the returned data sequence. (The final byte is the 962nd byte for BA and BB and is the only byte for MS.)

Pressing RESET on HP-IB controllers generates an interface clear (IFC) command on the bus, which unaddresses the analyzer.

In case an illegal two-character mnemonic is entered (i.e., one which is not part of the analyzer's command set), a message appears on the upper annotation line:

### SYNTAX ERROR

To remove the message, send a command AU, or press CLEAR/RESET and hold it in until the annotation returns to the control setting mode.

**AL, AU** Display lower line, display upper line control settings

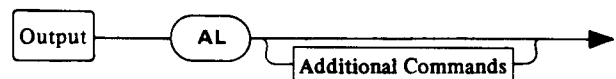

Returns labeling above graticule on CRT to the control setting mode after an LL or LU command. (AU = upper line, AL = lower line)

**AP, BP** Output coordinates of trace A, trace B peak

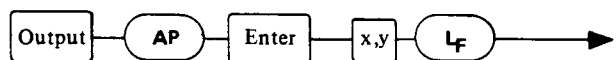

x,y: x,y coordinates (0-480, 0-820) of peak response on trace (AP = trace A, BP = trace B). Format is two 3-digit numbers separated by a comma:

$$\underbrace{d\ d\ d}_x, \underbrace{d\ d\ d}_y$$

If the peak value occurs at two or more horizontal positions, the leftmost point is returned.

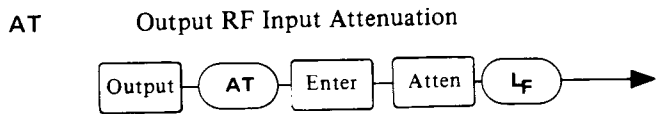

Atten: 0 to 70 for Attenuation in dB

**AU** See **AL**

**BA, BB** Output trace A, output trace B byte values

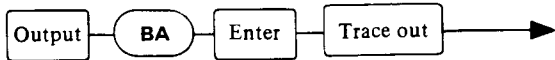

Trace out: 481 trace values (962 bytes) in double-byte format (BA = trace A, BB = trace B):

	ab	ab	ab	.....	ab	ab
value number	1	2	3	.....	480	481

where a and b are 8-bit bytes. Ten bits are required to specify trace values from 0 to 820 display units. 800 represents full-scale deflection. 801-820 are overrange values. The first byte in each number (a) represents the most significant two bits. The second byte (b) represents the least significant eight bits of this 10-bit value. For example, to represent 820, the pair of 8-bit bytes would be:

a = 00000011  
b = 00110100

Therefore, when a BA or BB command initiates a byte transfer over the interface, the resulting pairs of bytes must be recombined in the controller to yield meaningful data. Normally, the first byte is either shifted or rotated 8 bits to the left (or multiplied by  $256 = 2^8$ ) and added to the second byte to effect the recombination.

**BB** See **BA**

**BP** See **AP**

**CF** Output Center Frequency



Frequency: -50000000 to 22600000000 for Center Frequency in Hz

**CS** Output annotation

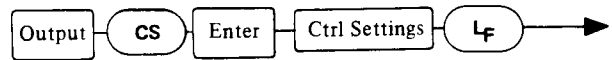

Ctrl settings: A 126-character string, represents two 63-character lines of control setting labels (or LL or LU generated labels) as they are displayed above the graticule on the analyzer CRT. Refer to LL, LU for a table of the character set.

**DG** Output display mode

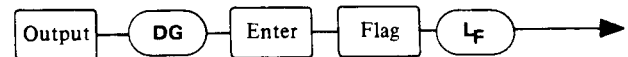

Flag: = 0 for normal mode  
= 1 for Digital Average mode

**DM** Output detection mode

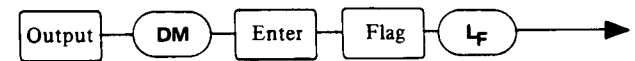

Flag: = 0 for Peak Detection mode  
= 1 for Sample mode

**IA, IB** Input trace A, input trace B integer values

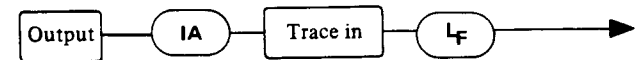

Trace in: Up to 481 values in the range 0-975. Only the integer portion of the number is used. Values will be displayed at the appropriate levels on the CRT except negative values, which will be blanked. The trace values are to be separated by commas, the last value followed by a semi-colon except when a full 481 values are sent, in which case the final semi-colon is optional. For example, an input of 300 values would look like this:

	v,	v,	v,	.....	v,	v;
value number	1	2	3	.....	299	300

where v = 1 to 3 digits

A carriage return before the terminating linefeed is optional and is ignored. If the trace values and commas are sent as a string, do not attempt to send additional commands following in the same 'Output' statement.



IB See IA

LG Output Amplitude Scale

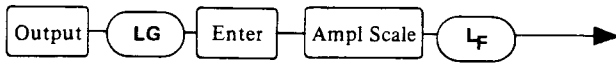

Ampl Scale: = 10, 5, 2, or 1 for LOG scale (dB/division)  
= 0 for LINEAR scale

LL, LU Input lower line, input upper line message

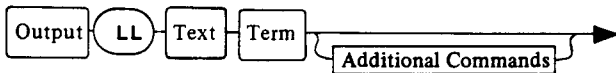

Text: Up to 63 ASCII characters to appear on upper line (LU) or lower line (LL) of labeling above graticule on CRT.

Term: An ASCII terminating character ETX, LF, CR or any byte in the range 0 to 31 decimal.

8569B Display Character Set

32*-63	!"#\$%&'<>+,-./0123456789:;<=>?
64-95	@ABCDEFGHIJKLMNPQRSTUVWXYZ[\]^_
96-127	`abcdefghijklmnopqrstuvwxyz{ }~

\*Character 32 is a blank

LU See LL

MS Output value of sweep flag



Flag: = 0 for sweep completed  
= 1 for sweep in progress

The MS (mid-sweep) flag should be used only following an SF command and refers only to the single sweep triggered by that command. If the MS flag is tested when there has been no SF command, the flag has no meaning and a zero value is returned.

NS Output INP-B→A state



Flag: = 0 for INP-B→A OFF  
= 1 for INP-B→A ON

RB Output Resolution Bandwidth

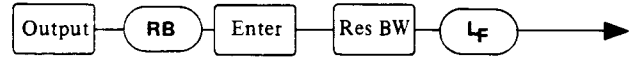

Res BW: = 100 to 3000000 for Resolution Bandwidth in Hz

RL Output Reference Level

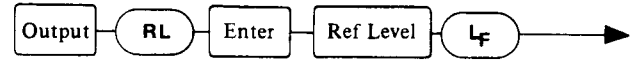

Ref Level: = 60 to -112 for Reference Level in dBm  
= 167 to -5 for Reference Level in dBμV\*  
= 172 to -172 for relative level of center graticule in dB with INP-B→A ON

SF Start sweep and set sweep flag

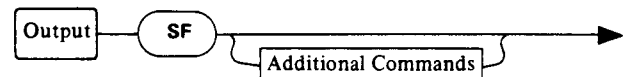

Triggers sweep, sets MS flag = 1. At completion of sweep, MS flag = 0. (SF may not be used when analyzer is in analog or mixed sweep mode.) During the sweep triggered by SF, the MS command may be used to test whether the sweep is in progress or complete. All other analyzer commands sent by the controller during the sweep for which the MS flag = 1 will be accepted and ignored by the analyzer. The MS command is the only command that has meaning during an SF-triggered sweep. See the example at the end of this appendix.

SP Output Frequency Span/Div



Span: = 1000 to 500000000 for Span in Hz/division  
= 0 for Zero Span  
= -1 for Full Span  
= -2 for 1.7-22 GHz Span

\*See Appendix D for conversion from dBm readout to dBμV.

**ST** Output Sweep Time/Div

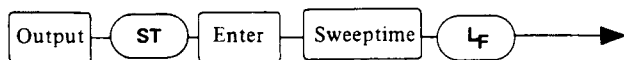

Sweeptime: = 2 to 10000000 for Sweeptime in  $\mu$ s/division  
 = -1 for AUTO sweep  
 = -2 for MANual sweep  
 = -3 for EXTernal sweep

**TA, TB** Output trace A, output trace B integer values

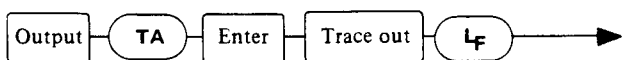

Trace out: 481 values in the range 000 to 820 (3 digits each including leading zeros), each value followed by a comma except the last value (1923 total bytes or ASCII characters).  
 (TA = trace A, TB = trace B.)

value number      v, v, v, . . . . . v, v;  
 1    2    3 . . . . . 480 481

where v = 3 digits

**TB** See TA

**TS** Take Sweep

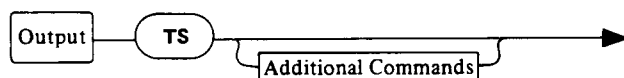

Triggers the analyzer to sweep and inhibits subsequent commands to the analyzer until that sweep is complete. Upon completion of the sweep, the analyzer resumes accepting commands normally. (TS may not be used when analyzer is in analog or mixed sweep mode.)

**VF** Output Video Filter



Video Filter: = .3 to .003 for ratio of VF to Res BW  
 = -1 for VF 1 Hz (noise average)  
 = -2 for VF OFF

An understanding of the interaction among six of the commands will facilitate their proper utilization in a user's program.

**EXAMPLE 1**

Two of these are SF and MS, which provide the user with additional flexibility in sweep control over that provided by the simpler TS command\*. When the analyzer receives the ASCII mnemonic TS, a sweep is triggered and no further commands are accepted until the sweep is finished. This allows a programmer to instruct the analyzer to obtain trace data for the current control settings and input signal conditions without interference from any subsequent commands.

To permit parallel usage of the controller and other HP-IB equipment while the analyzer is sweeping, followed by end-of-sweep program branching, use SF and MS.

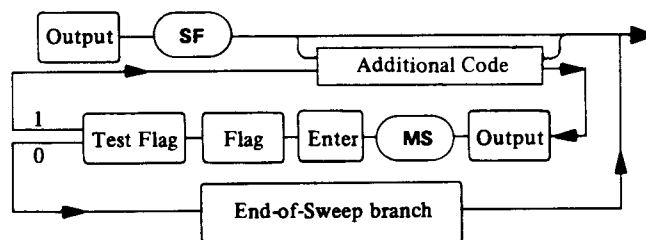

In the flow diagram, the SF instruction triggers a sweep and sets the MS flag = 1. The block Additional Code might represent digital processing of trace data from a previous sweep, or the execution of a separate measurement involving the controller and other instruments on the interface bus. If branching is desired at the end of the sweep (such as outputting the new trace data to the controller and triggering another sweep), the analyzer may be interrogated repeatedly to test the MS flag (the flag remains one for the duration of the sweep and then reverts to zero). Recognition of the zero condition leads to the 'End-of-Sweep branch' command.

It should be understood clearly that for the duration of an SF-triggered sweep (i.e., so long as the MS flag=1) only the specific instruction MS should be sent to the analyzer; any other command sent to the analyzer will be read and discarded. Therefore, resume sending other commands only after the MS flag has returned a zero.

\*For this discussion the analyzer is assumed to be in single-sweep trigger mode while executing controller generated sweep instructions TS and SF.

## EXAMPLE 2

The four remaining instructions requiring further explanation are two pairs; LL,LU and AL,AU. As LL with AL and LU with AU perform identical functions for their respective lines (lower and upper), only LL and AL is discussed.

Two lines of annotation are displayed above the etched CRT graticule. These may be the turn-on state in which the instrument control settings are displayed, or in a user-enabled state where the labeling lines have been input through the use of LL and LU. To reset the labels to the

control setting mode, AL and AU are provided. Thus, to place the label "8569A Spectrum Analyzer" on the lower line use:

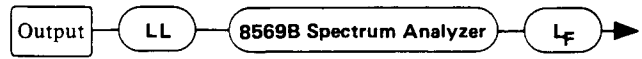

To subsequently reset the lower line to the control setting mode:



## APPENDIX F CONTROL GLOSSARY

### Front Panel

1. **LINE:** AC line switch. Turns instrument primary power ON-OFF.
2. **FOCUS:** Adjusts sharpness of CRT trace.
3. **TRACE ALIGN:** Rotates trace about center of CRT.
4. **HORIZ POSN:** Adjusts horizontal position of CRT trace.
5. **VERT POSN:** Adjusts vertical position of CRT trace.
6. **CLEAR/RESET:** Momentarily pressing CLEAR/RESET clears trace data in WRITE and MAX HOLD operation and resets sweep. Resets digital averaging routine to begin averaging of subsequent sweeps. Also resets INP – B→A. Aborts plot during plot mode. Clears display from HP-IB control. Holding CLEAR/RESET push button for 2 seconds returns control settings annotation to CRT.
7. **TRACE A, B:** Provides two independent digital traces in the following modes.
  - a. **WRITE:** Displays current input signal with each sweep.
  - b. **MAX HOLD:** Displays only the highest value of trace data over successive sweeps. Process restarted by pressing  CLEAR/RESET.
  - c. **STORE VIEW:** Stores current trace and displays it on CRT.
  - d. **STORE BLANK:** Stores current trace without displaying it on CRT. When both STORE BLANK buttons are pressed, analog display appears.
8. **SAMPLE:** Selects sample detection mode for random noise measurements (see Chapter 2).
9. **DGTL AVG:** Digitally averages trace data over successive sweeps. Maximum averaging achieved after 64 sweeps. Sample detection mode automatically selected.
10. **INP – B→A:** Subtracts trace data stored in TRACE B from input signal data and displays resulting data in Trace A. Normalized trace is at the center horizontal graticule line when input signal is equal to stored Trace B (see Chapter 2). Center line reference level (MID) changes to dB for relative measurements.
11. **PLOT:** Provides control of HP-IB plotter set for Listen Only mode. Display information is frozen on screen during plot. Use CLEAR/RESET to abort plot and return to local control.
  - a. GRAT plots graticule.
  - b. CHAR plots CRT control readouts or HP-IB entered message.
  - c. TRACE plots displayed trace(s).
12. **SCALE INTEN:** Adjusts background illumination for photography. Set to blue area for CRT photographs. Does not operate in ANALOG DSPL mode.
13. **INTEN:** Adjusts brightness of CRT trace and characters. Set to the blue region for CRT photographs.
14. **1ST LO OUTPUT:** A 2.0 to 4.46 GHz, +7 dBm nominal output coupled from first local oscillator. Terminate with 50Ω load when not in use. (Refer to Appendix B for information on LO for each Frequency Band.)
15. **CAL OUTPUT:** An internal 100 MHz, –10 dBm (+97 dBμV) calibration signal.
16. **SIG IDENT:** Used to verify frequency of unknown signals. Especially useful in External Mixing bands.
17. **VIDEO FILTER:** Selects post-detection, low-pass filters which smooth the trace by averaging random noise. The Video Filter bandwidth is equal to the Resolution BW times the factor indicated on the control knob. The NOISE AVG position is a fixed 1 Hz low-pass filter used for noise measurements only.
18. **FREQUENCY GHz:** Displays the tuned center frequency of analyzer in PER DIV and ZERO SPAN. In Full Band modes, displays frequency of the tuning marker.